

SHRINK

TOOL HOLDERS

Shrink Fit Chuck Working Principle

热缩刀柄的工作原理

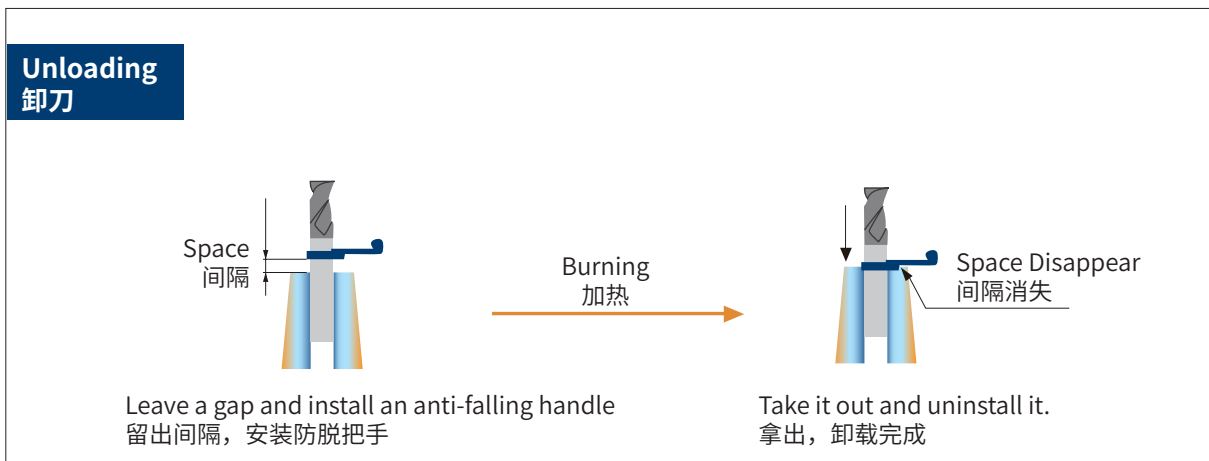
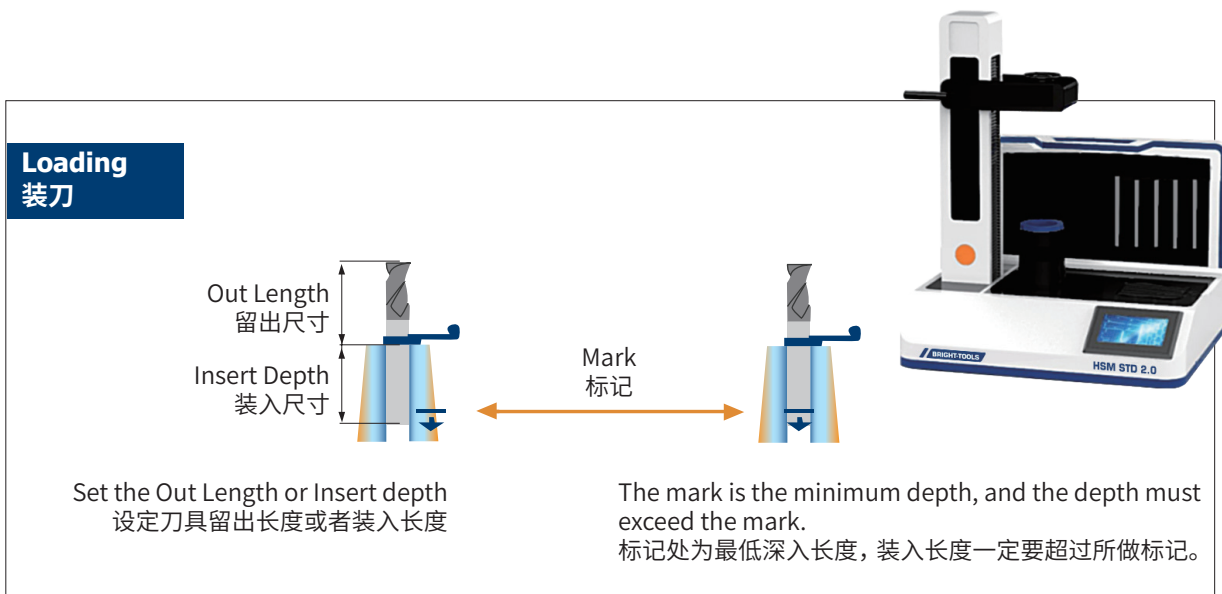
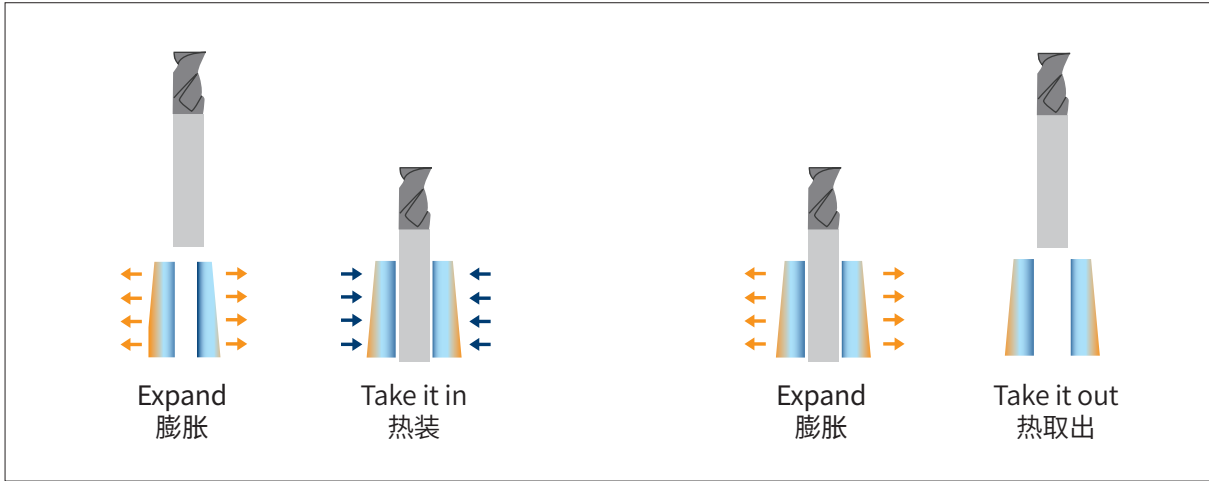

Shrink Fit Chuck Advantages 热缩刀柄加工优势

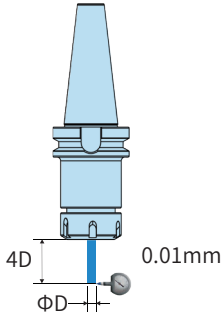
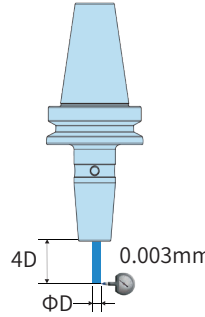
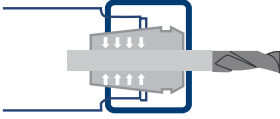
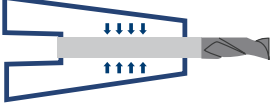
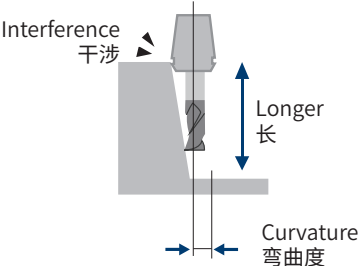
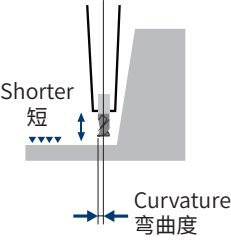
High Precision 高精度	High Precision 高精度
<p data-bbox="396 389 639 422">Collet Chuck ER 刀柄</p> 	<p data-bbox="980 389 1276 422">Shrink Fit Chuck 热缩刀柄</p> 
High Clamping Force 高夹持力	High Clamping Force 高夹持力
<p data-bbox="396 891 639 924">Collet Chuck ER 刀柄</p>  <p data-bbox="337 1130 678 1181">Elastic Deformation 通过 ER 筒夹内部的变形来夹持刀具</p>	<p data-bbox="980 891 1276 924">Shrink Fit Chuck 热缩刀柄</p>  <p data-bbox="911 1130 1321 1181">Thermal Expansion Contractility 利用了热胀冷缩的原理来增加和稳定夹持力</p>
Deep Cavity Machining 深孔加工 防干涉	Deep Cavity Machining 深孔加工 防干涉
<p data-bbox="396 1282 639 1316">Collet Chuck ER 刀柄</p>  <p data-bbox="326 1362 440 1395">Interference 干涉</p> <p data-bbox="581 1440 651 1490">Longer 长</p> <p data-bbox="586 1566 688 1616">Curvature 弯曲度</p>	<p data-bbox="980 1282 1276 1316">Shrink Fit Chuck 热缩刀柄</p>  <p data-bbox="1024 1446 1094 1497">Shorter 短</p> <p data-bbox="1154 1557 1256 1608">Curvature 弯曲度</p>

Shrink Fit Chuck Coolant Outlet Method 热缩刀柄出水方式

AD 中心出水



Face Outlet 端面出水



AD+B 中心 + 法兰出水



SHRINK TOOLING SYSTEM

热缩工具系统

BT Shrink Fit Chuck, Standard, 4.5°A.06 BT 热缩刀柄, 标准型	BT Shrink Chuck TaperA.61 BT 分体热缩本体, 标准型
BBT Shrink Fit Chuck, Standard, 4.5°A.11 BBT 热缩刀柄, 标准型	SK Shrink Chuck TaperA.62 SK 分体热缩本体, 标准型
SK Shrink Fit Chuck, Standard, 4.5°A.14 SK 热缩刀柄, 标准型	HSK-A Shrink Chuck TaperA.63 HSK-A 分体热缩本体, 标准型
CAT Shrink Fit Chuck, Standard, 4.5°A.18 CAT 热缩刀柄, 标准型	HSK-E Shrink Chuck TaperA.64 HSK-E 分体热缩本体, 标准型
HSK-A Shrink Fit Chuck, Standard, 4.5°A.23 HSK-A 热缩刀柄, 标准型	HSK-F Shrink Chuck TaperA.65 HSK-F 分体热缩本体, 标准型
HSK-E Shrink Fit Chuck, Standard, 4.5°A.30 HSK-E 热缩刀柄, 标准型	BT Shrink Chuck Taper, Coooolant.....A.66 BT 分体热缩本体, 端面出水型
HSK-F Shrink Fit Chuck, Standard, 4.5°A.32 HSK-F 热缩刀柄, 标准型	SK Shrink Chuck Taper, Coooolant.....A.66 SK 分体热缩本体, 端面出水型
BT Shrink Fit Chuck, 4.5°, Coolant A.34 BT 热缩刀柄, 端面出水型	HSK Shrink Chuck Taper, Coooolant.....A.67 HSK 分体热缩本体, 端面出水型
BBT Shrink Fit Chuck, 4.5°, Coolant A.36 BBT 热缩刀柄, 端面出水型	Shrink Chuck Extension Slim.....A.68 分体热缩延长杆, 细长型
SK Shrink Fit Chuck, 4.5°, Coolant A.38 SK 热缩刀柄, 端面出水型	Shrink Chuck Extension, Standard.....A.70 分体热缩延长杆, 标准型
CAT Shrink Fit Chuck, 4.5°, Coolant A.40 CAT 热缩刀柄, 端面出水型	Shrink Chuck Extension, Coolant.....A.72 分体热缩延长杆, 端面出水型
HSK Shrink Fit Chuck, 4.5°, Coolant A.45 HSK 热缩刀柄, 端面出水型	Shrink Chuck Set.....A.72 热缩刀柄套装
BT Shrink Fit Chuck, Slim, 3°A.48 BT 热缩刀柄 3 度, 细长型	Heating MachineA.73 热缩机
SK Shrink Fit Chuck, Slim, 3° A.49 SK 热缩刀柄 3 度, 细长型	
CAT Shrink Fit Chuck, Slim, 3° A.50 CAT 热缩刀柄 3 度, 细长型	
HSK-A Shrink Fit Chuck, Slim, 3° A.51 HSK-A 热缩刀柄 3 度, 细长型	
HSK-E Shrink Fit Chuck, Slim, 3° A.53 HSK-E 热缩刀柄 3 度, 细长型	
Shrink Fit Extension, 3°.....A.55 3° 直柄热缩延长杆	
Module Shrink Chuck.....A.57 法兰热缩刀柄	
Shrink Fit ER Collet.....A.58 ER 热缩夹头	
Shrink Fit ER Collet Extension.....A.59 ER 热缩延长杆	
Shrink Chuck Set.....A.60 热缩刀柄套装	



Shrink Fit Chuck, 4.5°, Standard

热缩刀柄, 标准型

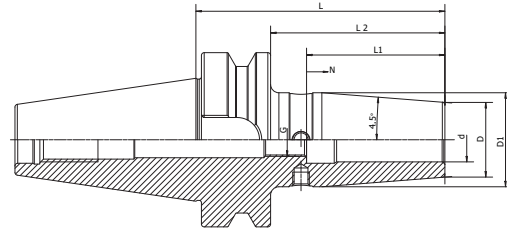
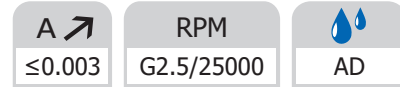

Size	d	D	D1	L	L2	L1	N	G
BT30-SF03-80	3	15	20	80	58	-	-	-
BT30-SF04-80	4	15	20	80	58	-	-	-
BT30-SF05-80	5	15	20	80	58	-	-	-
BT30-SF06-80	6	21	27	80	58	36	10	M5
BT30-SF08-80	8	21	27	80	58	36	10	M6
BT30-SF10-80	10	24	30.5	80	58	42	10	M8x1
BT30-SF12-80	12	24	30.5	80	58	47	10	M10x1
BT30-SF14-80	14	27	33.5	80	58	47	10	M10x1
BT30-SF16-80	16	27	33.5	80	58	50	10	M12x1
BT30-SF18-80	18	33	39.5	80	58	50	10	M12x1
BT30-SF20-80	20	33	39.5	80	58	52	10	M16x1
BT30-SF06-120	6	21	27	120	98	36	10	M5
BT30-SF08-120	8	21	27	120	98	36	10	M6
BT30-SF10-120	10	24	32	120	98	42	10	M8x1
BT30-SF12-120	12	24	32	120	98	47	10	M10x1
BT30-SF16-120	16	27	34	120	98	50	10	M12x1
BT30-SF20-120	20	33	42	120	98	52	10	M16x1
BT40-SF03-80	3	15	20	80	53	-	-	-
BT40-SF04-80	4	15	20	80	53	-	-	-
BT40-SF05-80	5	15	20	80	53	-	-	-
BT40-SF06-90	6	21	27	90	63	36	10	M5
BT40-SF08-90	8	21	27	90	63	36	10	M6
BT40-SF10-90	10	24	31	90	63	42	10	M8x1
BT40-SF12-90	12	24	31	90	63	47	10	M10x1
BT40-SF14-90	14	27	34	90	63	47	10	M10x1
BT40-SF16-90	16	27	34	90	63	50	10	M12x1
BT40-SF18-90	18	33	40	90	63	50	10	M12x1
BT40-SF20-90	20	33	40	90	63	52	10	M16x1
BT40-SF25-100	25	44	53	100	73	58	10	M16x1
BT40-SF32-100	32	44	53	100	73	62	10	M16x1
BT40-SF03-120	3	15	20	120	93	-	-	-
BT40-SF04-120	4	15	20	120	93	-	-	-
BT40-SF05-120	5	15	20	120	93	-	-	-
BT40-SF06-120	6	21	27	120	93	36	10	M5

Shrink Fit Chuck, 4.5°, Standard
热缩刀柄, 标准型

A ↗ ≤0.003	RPM G2.5/25000	AD
---------------	-------------------	----

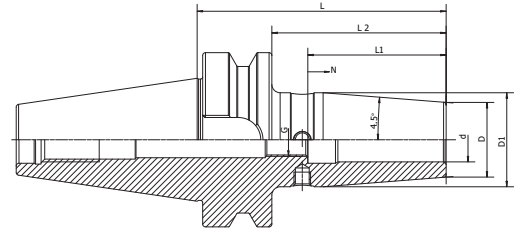

Size	d	D	D1	L	L2	L1	N	G
BT40-SF08-120	8	21	27	120	93	36	10	M6
BT40-SF10-120	10	24	32	120	93	42	10	M8x1
BT40-SF12-120	12	24	32	120	93	47	10	M10x1
BT40-SF14-120	14	27	34	120	93	47	10	M10x1
BT40-SF16-120	16	27	34	120	93	50	10	M12x1
BT40-SF18-120	18	33	42	120	93	50	10	M12x1
BT40-SF20-120	20	33	42	120	93	52	10	M16x1
BT40-SF25-120	25	44	53	120	93	58	10	M16x1
BT40-SF32-120	32	44	53	120	93	62	10	M16x1
BT40-SF03-160	3	15	25	160	133	-	-	-
BT40-SF04-160	4	15	25	160	133	-	-	-
BT40-SF05-160	5	15	25	160	133	-	-	-
BT40-SF06-160	6	21	32	160	133	36	10	M5
BT40-SF08-160	8	21	32	160	133	36	10	M6
BT40-SF10-160	10	24	34	160	133	42	10	M8x1
BT40-SF12-160	12	24	34	160	133	47	10	M10x1
BT40-SF14-160	14	27	42	160	133	47	10	M10x1
BT40-SF16-160	16	27	42	160	133	50	10	M12x1
BT40-SF18-160	18	33	51	160	133	50	10	M12x1
BT40-SF20-160	20	33	51	160	133	52	10	M16x1
BT40-SF25-160	25	44	53	160	133	58	10	M16x1
BT40-SF32-160	32	44	60	160	133	62	10	M16x1
BT40-SF06-200	6	21	32	200	173	36	10	M5
BT40-SF08-200	8	21	32	200	173	36	10	M6
BT40-SF10-200	10	24	34	200	173	42	10	M8x1
BT40-SF12-200	12	24	34	200	173	47	10	M10x1
BT40-SF14-200	14	27	42	200	173	47	10	M10x1
BT40-SF16-200	16	27	42	200	173	50	10	M12x1
BT40-SF18-200	18	33	51	200	173	50	10	M12x1
BT40-SF20-200	20	33	51	200	173	52	10	M16x1
BT40-SF25-200	25	44	53	200	173	58	10	M16x1
BT40-SF32-200	32	44	60	200	173	62	10	M16x1

Shrink Fit Chuck, 4.5°, Standard

热缩刀柄, 标准型

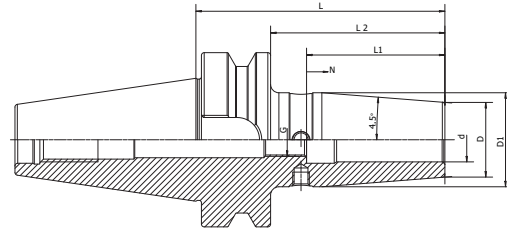
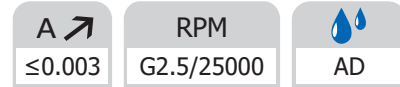

Size	d	D	D1	L	L2	L1	N	G
BT50-SF03-100	3	15	20	100	62	-	-	-
BT50-SF04-100	4	15	20	100	62	-	-	-
BT50-SF05-100	5	15	20	100	62	-	-	-
BT50-SF06-100	6	21	27	100	62	36	10	M5
BT50-SF08-100	8	21	27	100	62	36	10	M6
BT50-SF10-100	10	24	30.5	100	62	42	10	M8x1
BT50-SF12-100	12	24	30.5	100	62	47	10	M10x1
BT50-SF14-100	14	27	34	100	62	47	10	M10x1
BT50-SF16-100	16	27	34	100	62	50	10	M12x1
BT50-SF18-100	18	33	40	100	62	50	10	M12x1
BT50-SF20-100	20	33	40	100	62	52	10	M16x1
BT50-SF03-120	3	15	20	120	82	-	-	-
BT50-SF04-120	4	15	20	120	82	-	-	-
BT50-SF05-120	5	15	20	120	82	-	-	-
BT50-SF06-120	6	21	27	120	82	36	10	M5
BT50-SF08-120	8	21	27	120	82	36	10	M6
BT50-SF10-120	10	24	32	120	82	42	10	M8x1
BT50-SF12-120	12	24	32	120	82	47	10	M10x1
BT50-SF14-120	14	27	34	120	82	47	10	M10x1
BT50-SF16-120	16	27	34	120	82	50	10	M12x1
BT50-SF18-120	18	33	42	120	82	50	10	M12x1
BT50-SF20-120	20	33	42	120	82	52	10	M16x1
BT50-SF25-120	25	44	53	120	82	58	10	M16x1
BT50-SF32-120	32	44	53	120	82	62	10	M16x1

Shrink Fit Chuck, 4.5°, Standard
热缩刀柄, 标准型

A ↗ ≤0.003	RPM G2.5/25000	AD
---------------	-------------------	----

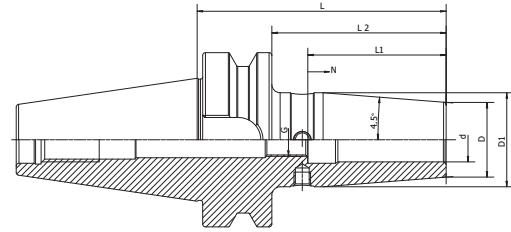

Size	d	D	D1	L	L2	L1	N	G
BT50-SF03-160	3	15	25	160	122	-	-	-
BT50-SF04-160	4	15	25	160	122	-	-	-
BT50-SF05-160	5	15	25	160	122	-	-	-
BT50-SF06-160	6	21	32	160	122	36	10	M5
BT50-SF08-160	8	21	32	160	122	36	10	M6
BT50-SF10-160	10	24	34	160	122	42	10	M8x1
BT50-SF12-160	12	24	34	160	122	47	10	M10x1
BT50-SF14-160	14	27	42	160	122	47	10	M10x1
BT50-SF16-160	16	27	42	160	122	50	10	M12x1
BT50-SF18-160	18	33	49	160	122	50	10	M12x1
BT50-SF20-160	20	33	49	160	122	52	10	M16x1
BT50-SF25-160	25	44	60	160	122	58	10	M16x1
BT50-SF32-160	32	44	60	160	122	62	10	M16x1
BT50-SF06-200	6	21	32	200	162	36	10	M5
BT50-SF08-200	8	21	32	200	162	36	10	M6
BT50-SF10-200	10	24	34	200	162	42	10	M8x1
BT50-SF12-200	12	24	34	200	162	47	10	M10x1
BT50-SF14-200	14	27	42	200	162	47	10	M10x1
BT50-SF16-200	16	27	42	200	162	50	10	M12x1
BT50-SF18-200	18	33	51	200	162	50	10	M12x1
BT50-SF20-200	20	33	51	200	162	52	10	M16x1
BT50-SF25-200	25	44	60	200	162	58	10	M16x1
BT50-SF32-200	32	44	60	200	162	62	10	M16x1
BT50-SF06-250	6	21	32	250	212	36	10	M5
BT50-SF08-250	8	21	32	250	212	36	10	M6
BT50-SF10-250	10	24	34	250	212	42	10	M8x1
BT50-SF12-250	12	24	34	250	212	47	10	M10x1
BT50-SF16-250	16	27	42	250	212	50	10	M12x1
BT50-SF18-250	18	33	51	250	212	50	10	M12x1
BT50-SF20-250	20	33	51	250	212	52	10	M16x1
BT50-SF25-250	25	44	60	250	212	58	10	M16x1
BT50-SF32-250	32	44	60	250	212	62	10	M16x1

Shrink Fit Chuck, 4.5°, Standard

热缩刀柄, 标准型

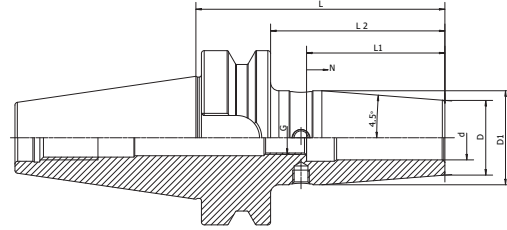
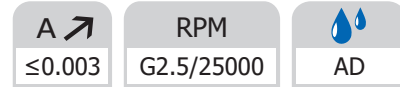

Size	d	D	D1	L	L2	L1	N	G
BT30-SF1/4"-3.15"	1/4"	0.83"	1.06"	3.15"	2.28"	1.42"	0.39"	M5
BT30-SF3/8"-3.15"	3/8"	0.95"	1.26"	3.15"	2.28"	1.65"	0.39"	M8 x 1
BT30-SF1/2"-3.15"	1/2"	0.94"	1.34"	3.15"	2.28"	1.85"	0.39"	M10 x 1
BT30-SF5/8"-3.15"	5/8"	1.06"	1.34"	3.15"	2.28"	1.97"	0.39"	M12 x 1
BT30-SF3/4"-3.15"	3/4"	1.29"	1.62"	3.15"	2.28"	2.04"	0.39"	M16 x 2.0
BT40-SF3/16"-3.54	3/16"	0.43"	0.75"	3.54"	2.67"	0.79"	-	M6 x 1.0
BT40-SF1/4"-3.54	1/4"	0.82"	1.06"	3.54"	2.67"	1.42"	0.39"	M5 x 0.8
BT40-SF3/8"-3.54	3/8"	0.94"	1.25"	3.54"	2.67"	1.65"	0.39"	-
BT40-SF1/2"-3.54	1/2"	1.10"	1.34"	3.54"	2.67"	1.85"	0.39"	M10 x 1.5
BT40-SF5/8"-3.54	5/8"	1.06"	1.34"	3.54"	2.67"	1.96"	0.39"	M12 x 1.75
BT40-SF3/4"-3.54	3/4"	1.29"	1.65"	3.54"	2.67"	2.04"	0.39"	M16 x 2.0
BT40-SF1.0"-3.54	1.0"	1.73"	2.08"	3.54"	2.67"	2.28"	0.39"	M20 x 2.0
BT40-SF1-1/4"-4.13	1-1/4"	1.81"	2.08"	4.13"	3.26"	2.28"	0.39"	M20 x 2.0
BT40-SF1/8"-6.3"	1/8"	0.36"	0.63"	6"	5.13"	0.70"	-	M6 x 1.0
BT40-SF3/16"-6.3"	3/16"	0.43"	0.70"	6"	5.13"	0.79"	-	M6 x 1.0
BT40-SF1/4"-6.3"	1/4"	0.49"	0.83"	6"	5.13"	1.42"	0.39"	M5 x 0.8
BT40-SF3/8"-6.3"	3/8"	0.61"	0.94"	6"	5.13"	1.65"	0.39"	M8 x 1.25
BT40-SF1/2"-6.3"	1/2"	0.74"	1.06"	6"	5.13"	1.85"	0.39"	M10 x 1.5
BT40-SF5/8"-6.3"	5/8"	1.06"	1.34"	6"	5.13"	1.96"	0.39"	M12 x 1.75
BT40-SF3/4"-6.3"	3/4"	1.29"	1.65"	6"	5.13"	1.65"	0.39"	M16 x 2.0
BT40-SF1"-6.3"	1"	1.73"	2.09"	6"	5.13"	2.28"	0.39"	M20 x 2.0

Shrink Fit Chuck, 4.5°, Standard
热缩刀柄, 标准型

A ↗ ≤0.003	RPM G2.5/25000	AD
---------------	-------------------	----

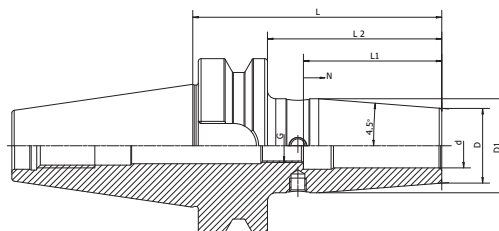

Size	d	D	D1	L	L2	L1	N	G
BBT40-SF03-80	3	15	20	80	53	-	-	-
BBT40-SF04-80	4	15	20	80	53	-	-	-
BBT40-SF05-80	5	15	20	80	53	-	-	-
BBT40-SF06-90	6	21	27	90	63	36	10	M5
BBT40-SF08-90	8	21	27	90	63	36	10	M6
BBT40-SF10-90	10	24	31	90	63	42	10	M8x1
BBT40-SF12-90	12	24	31	90	63	47	10	M10x1
BBT40-SF14-90	14	27	34	90	63	47	10	M10x1
BBT40-SF16-90	16	27	34	90	63	50	10	M12x1
BBT40-SF18-90	18	33	40	90	63	50	10	M12x1
BBT40-SF20-90	20	33	40	90	63	52	10	M16x1
BBT40-SF25-100	25	44	53	100	73	58	10	M16x1
BBT40-SF32-100	32	44	53	100	73	62	10	M16x1
BBT40-SF03-120	3	15	20	120	93	-	-	-
BBT40-SF04-120	4	15	20	120	93	-	-	-
BBT40-SF05-120	5	15	20	120	93	-	-	-
BBT40-SF06-120	6	21	27	120	93	36	10	M5
BBT40-SF08-120	8	21	27	120	93	36	10	M6
BBT40-SF10-120	10	24	32	120	93	42	10	M8x1
BBT40-SF12-120	12	24	32	120	93	47	10	M10x1
BBT40-SF14-120	14	27	34	120	93	47	10	M10x1
BBT40-SF16-120	16	27	34	120	93	50	10	M12x1
BBT40-SF18-120	18	33	42	120	93	50	10	M12x1
BBT40-SF20-120	20	33	42	120	93	52	10	M16x1
BBT40-SF25-120	25	44	53	120	93	58	10	M16x1
BBT40-SF32-120	32	44	53	120	93	62	10	M16x1

Shrink Fit Chuck, 4.5°, Standard

热缩刀柄, 标准型

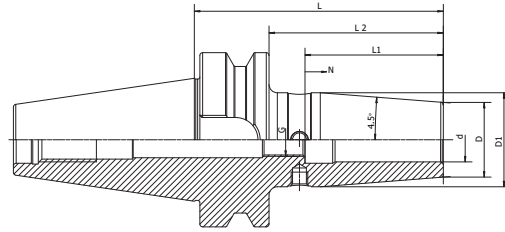
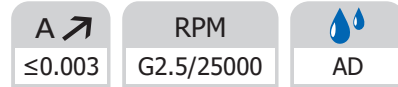

Size	d	D	D1	L	L2	L1	N	G
BBT40-SF03-160	3	15	25	160	133	-	-	-
BBT40-SF04-160	4	15	25	160	133	-	-	-
BBT40-SF05-160	5	15	25	160	133	-	-	-
BBT40-SF06-160	6	21	32	160	133	36	10	M5
BBT40-SF08-160	8	21	32	160	133	36	10	M6
BBT40-SF10-160	10	24	34	160	133	42	10	M8x1
BBT40-SF12-160	12	24	34	160	133	47	10	M10x1
BBT40-SF14-160	14	27	42	160	133	47	10	M10x1
BBT40-SF16-160	16	27	42	160	133	50	10	M12x1
BBT40-SF18-160	18	33	51	160	133	50	10	M12x1
BBT40-SF20-160	20	33	51	160	133	52	10	M16x1
BBT40-SF25-160	25	44	53	160	133	58	10	M16x1
BBT40-SF32-160	32	44	60	160	133	62	10	M16x1
BBT50-SF03-100	3	15	20	100	62	-	-	-
BBT50-SF04-100	4	15	20	100	62	-	-	-
BBT50-SF05-100	5	15	20	100	62	-	-	-
BBT50-SF06-100	6	21	27	100	62	36	10	M5
BBT50-SF08-100	8	21	27	100	62	36	10	M6
BBT50-SF10-100	10	24	30.5	100	62	42	10	M8x1
BBT50-SF12-100	12	24	30.5	100	62	47	10	M10x1
BBT50-SF14-100	14	27	34	100	62	47	10	M10x1
BBT50-SF16-100	16	27	34	100	62	50	10	M12x1
BBT50-SF18-100	18	33	40	100	62	50	10	M12x1
BBT50-SF20-100	20	33	40	100	62	52	10	M16x1
BBT50-SF25-120	25	44	53	120	82	58	10	M16x1
BBT50-SF32-120	32	44	53	120	82	62	10	M16x1

Shrink Fit Chuck, 4.5°, Standard
热缩刀柄, 标准型

A ↗ ≤0.003	RPM G2.5/25000	AD
---------------	-------------------	----

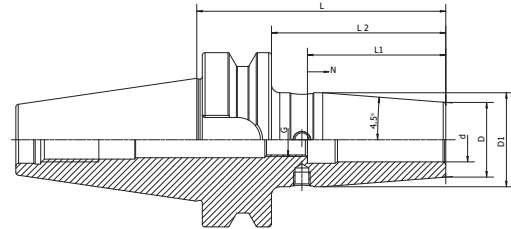

Size	d	D	D1	L	L2	L1	N	G
BBT50-SF03-120	3	15	20	120	82	-	-	-
BBT50-SF04-120	4	15	20	120	82	-	-	-
BBT50-SF05-120	5	15	20	120	82	-	-	-
BBT50-SF06-120	6	21	27	120	82	36	10	M5
BBT50-SF08-120	8	21	27	120	82	36	10	M6
BBT50-SF10-120	10	24	32	120	82	42	10	M8x1
BBT50-SF12-120	12	24	32	120	82	47	10	M10x1
BBT50-SF14-120	14	27	34	120	82	47	10	M10x1
BBT50-SF16-120	16	27	34	120	82	50	10	M12x1
BBT50-SF18-120	18	33	42	120	82	50	10	M12x1
BBT50-SF20-120	20	33	42	120	82	52	10	M16x1
BBT50-SF03-160	3	15	25	160	122	-	-	-
BBT50-SF04-160	4	15	25	160	122	-	-	-
BBT50-SF05-160	5	15	25	160	122	-	-	-
BBT50-SF06-160	6	21	32	160	122	36	10	M5
BBT50-SF08-160	8	21	32	160	122	36	10	M6
BBT50-SF10-160	10	24	34	160	122	42	10	M8x1
BBT50-SF12-160	12	24	34	160	122	47	10	M10x1
BBT50-SF14-160	14	27	42	160	122	47	10	M10x1
BBT50-SF16-160	16	27	42	160	122	50	10	M12x1
BBT50-SF18-160	18	33	49	160	122	50	10	M12x1
BBT50-SF20-160	20	33	49	160	122	52	10	M16x1
BBT50-SF25-160	25	44	60	160	122	58	10	M16x1
BBT50-SF32-160	32	44	60	160	122	62	10	M16x1

Shrink Fit Chuck, 4.5°, Standard

热缩刀柄, 标准型

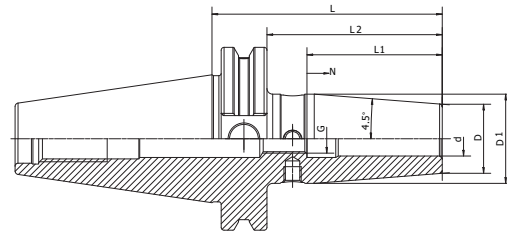
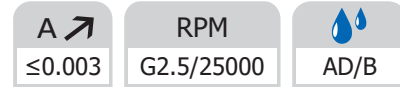

Size	d	D	D1	L	L2	L1	N	G
SK30-SF03-80	3	15	20	80	60.9	-	-	-
SK30-SF04-80	4	15	20	80	60.9	-	-	-
SK30-SF05-80	5	15	20	80	60.9	-	-	-
SK30-SF06-80	6	21	27	80	60.9	36	10	M5
SK30-SF08-80	8	21	27	80	60.9	36	10	M6
SK30-SF10-80	10	24	32	80	60.9	42	10	M8x1
SK30-SF12-80	12	24	32	80	60.9	47	10	M10x1
SK30-SF14-80	14	27	34	80	60.9	47	10	M10x1
SK30-SF16-80	16	27	34	80	60.9	50	10	M12x1
SK30-SF18-80	18	33	42	80	60.9	50	10	M12x1
SK30-SF20-80	20	33	42	80	60.9	52	10	M16x1
SK30-SF03-120	3	15	20	120	100.9	-	-	-
SK30-SF04-120	4	15	20	120	100.9	-	-	-
SK30-SF05-120	5	15	20	120	100.9	-	-	-
SK30-SF06-120	6	21	27	120	100.9	36	10	M5
SK30-SF08-120	8	21	27	120	100.9	36	10	M6
SK30-SF10-120	10	24	32	120	100.9	42	10	M8x1
SK30-SF12-120	12	24	32	120	100.9	47	10	M10x1
SK30-SF16-120	16	27	34	120	100.9	50	10	M12x1
SK40-SF03-80	3	15	20	80	60.9	-	-	-
SK40-SF04-80	4	15	20	80	60.9	-	-	-
SK40-SF05-80	5	15	20	80	60.9	-	-	-
SK40-SF06-80	6	21	27	80	60.9	36	10	M5
SK40-SF08-80	8	21	27	80	60.9	36	10	M6
SK40-SF10-80	10	24	31	80	60.9	42	10	M8x1
SK40-SF12-80	12	24	31	80	60.9	47	10	M10x1
SK40-SF14-80	14	27	34	80	60.9	47	10	M10x1
SK40-SF16-80	16	27	34	80	60.9	50	10	M12x1
SK40-SF18-80	18	33	40	80	60.9	50	10	M12x1
SK40-SF20-80	20	33	40	80	60.9	52	10	M16x1
SK40-SF25-100	25	44	50	100	80.9	58	10	M16x1
SK40-SF32-100	32	44	50	100	80.9	62	10	M16x1

Shrink Fit Chuck, 4.5°, Standard
热缩刀柄, 标准型

A ↗ ≤0.003	RPM G2.5/25000	AD/B
---------------	-------------------	------

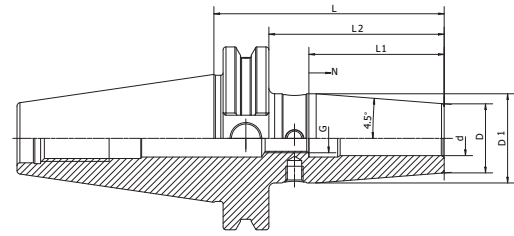

Size	d	D	D1	L	L2	L1	N	G
SK40-SF03-120	3	15	20	120	100.9	-	-	-
SK40-SF04-120	4	15	20	120	100.9	-	-	-
SK40-SF05-120	5	15	20	120	100.9	-	-	-
SK40-SF06-120	6	21	27	120	100.9	36	10	M5
SK40-SF08-120	8	21	27	120	100.9	36	10	M6
SK40-SF10-120	10	24	32	120	100.9	42	10	M8x1
SK40-SF12-120	12	24	32	120	100.9	47	10	M10x1
SK40-SF14-120	14	27	34	120	100.9	47	10	M10x1
SK40-SF16-120	16	27	34	120	100.9	50	10	M12x1
SK40-SF18-120	18	31	42	120	100.9	50	10	M12x1
SK40-SF20-120	20	31	42	120	100.9	52	10	M16x1
SK40-SF25-120	25	44	50	120	100.9	58	10	M16x1
SK40-SF03-160	3	15	20	160	140.9	-	-	-
SK40-SF04-160	4	15	20	160	140.9	-	-	-
SK40-SF05-160	5	15	20	160	140.9	-	-	-
SK40-SF06-160	6	21	32	160	140.9	36	10	M5
SK40-SF08-160	8	21	32	160	140.9	36	10	M6
SK40-SF10-160	10	24	34	160	140.9	42	10	M8x1
SK40-SF12-160	12	24	34	160	140.9	47	10	M10x1
SK40-SF14-160	14	27	42	160	140.9	47	10	M10x1
SK40-SF16-160	16	27	42	160	140.9	50	10	M12x1
SK40-SF18-160	18	33	50	160	140.9	50	10	M12x1
SK40-SF20-160	20	33	50	160	140.9	52	10	M16x1
SK40-SF25-160	25	44	50	160	140.9	58	10	M16x1
SK40-SF32-160	32	44	50	160	140.9	62	10	M16x1

Shrink Fit Chuck, 4.5°, Standard

热缩刀柄, 标准型

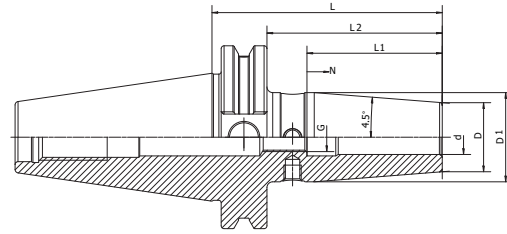
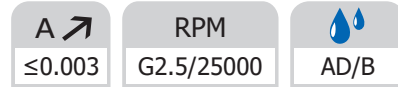

Size	d	D	D1	L	L2	L1	N	G
SK40-SF06-200	6	21	32	200	180.9	36	10	M5
SK40-SF08-200	8	21	32	200	180.9	36	10	M6
SK40-SF10-200	10	24	34	200	180.9	42	10	M8x1
SK40-SF12-200	12	24	34	200	180.9	47	10	M10x1
SK40-SF14-200	14	27	42	200	180.9	47	10	M10x1
SK40-SF16-200	16	27	42	200	180.9	50	10	M12x1
SK40-SF18-200	18	33	50	200	180.9	50	10	M12x1
SK40-SF20-200	20	33	50	200	180.9	52	10	M16x1
SK40-SF25-200	25	44	50	200	180.9	58	10	M16x1
SK40-SF32-200	32	44	50	200	180.9	62	10	M16x1
SK50-SF06-80	6	21	27	80	60.9	36	10	M5
SK50-SF08-80	8	21	27	80	60.9	36	10	M6
SK50-SF10-80	10	24	31	80	60.9	42	10	M8x1
SK50-SF12-80	12	24	31	80	60.9	47	10	M10x1
SK50-SF14-80	14	27	34	80	60.9	47	10	M10x1
SK50-SF16-80	16	27	34	80	60.9	50	10	M12x1
SK50-SF18-80	18	33	40	80	60.9	50	10	M12x1
SK50-SF20-80	20	33	39.5	80	60.9	52	10	M16x1
SK50-SF25-90	25	44	52.5	90	70.9	58	10	M16x1
SK50-SF32-90	32	44	52.5	90	70.9	62	10	M16x1

Shrink Fit Chuck, 4.5°, Standard
热缩刀柄, 标准型

A ↗ ≤0.003	RPM G2.5/25000	AD/B
---------------	-------------------	------

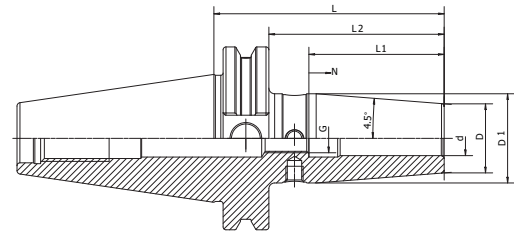

Size	d	D	D1	L	L2	L1	N	G
SK50-SF06-120	6	21	27	120	100.9	36	10	M5
SK50-SF08-120	8	21	27	120	100.9	36	10	M6
SK50-SF10-120	10	24	32	120	100.9	42	10	M8x1
SK50-SF12-120	12	24	32	120	100.9	47	10	M10x1
SK50-SF14-120	14	27	34	120	100.9	47	10	M10x1
SK50-SF16-120	16	27	34	120	100.9	50	10	M12x1
SK50-SF18-120	18	33	42	120	100.9	50	10	M12x1
SK50-SF20-120	20	33	42	120	100.9	52	10	M16x1
SK50-SF25-120	25	44	53	120	100.9	58	10	M16x1
SK50-SF32-120	32	44	53	120	100.9	62	10	M16x1
SK50-SF06-160	6	21	32	160	140.9	36	10	M5
SK50-SF08-160	8	21	32	160	140.9	36	10	M6
SK50-SF10-160	10	24	34	160	140.9	42	10	M8x1
SK50-SF12-160	12	24	34	160	140.9	47	10	M10x1
SK50-SF14-160	14	27	42	160	140.9	47	10	M10x1
SK50-SF16-160	16	27	42	160	140.9	50	10	M12x1
SK50-SF18-160	18	33	51	160	140.9	50	10	M12x1
SK50-SF20-160	20	33	51	160	140.9	52	10	M16x1
SK50-SF25-160	25	44	60	160	140.9	58	10	M16x1
SK50-SF32-160	32	44	60	160	140.9	62	10	M16x1
SK50-SF06-200	6	21	32	200	180.9	36	10	M5
SK50-SF08-200	8	21	32	200	180.9	36	10	M6
SK50-SF10-200	10	24	34	200	180.9	42	10	M8x1
SK50-SF12-200	12	24	34	200	180.9	47	10	M10x1
SK50-SF14-200	14	27	42	200	180.9	47	10	M10x1
SK50-SF16-200	16	27	42	200	180.9	50	10	M12x1
SK50-SF18-200	18	33	51	200	180.9	50	10	M12x1
SK50-SF20-200	20	33	51	200	180.9	52	10	M16x1
SK50-SF25-200	25	44	60	200	180.9	58	10	M16x1
SK50-SF32-200	32	44	60	200	180.9	62	10	M16x1

Shrink Fit Chuck, 4.5°, Standard

热缩刀柄, 标准型

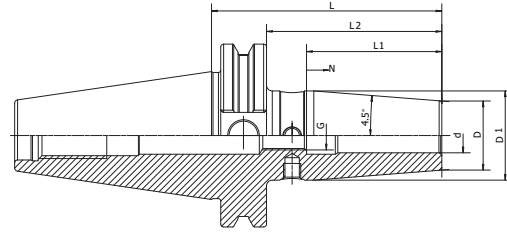
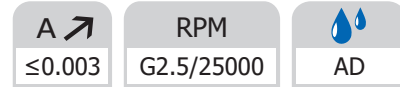

Size	d	D	D1	L	L2	L1	N	G
CAT40-SF03-80	3	15	20	80	60.9	-	-	-
CAT40-SF04-80	4	15	20	80	60.9	-	-	-
CAT40-SF05-80	5	15	20	80	60.9	-	-	-
CAT40-SF06-80	6	21	27	80	60.9	36	10	M5
CAT40-SF08-80	8	21	27	80	60.9	36	10	M6
CAT40-SF10-80	10	24	31	80	60.9	42	10	M8x1
CAT40-SF12-80	12	24	31	80	60.9	47	10	M10x1
CAT40-SF14-80	14	27	34	80	60.9	47	10	M10x1
CAT40-SF16-80	16	27	34	80	60.9	50	10	M12x1
CAT40-SF18-80	18	33	40	80	60.9	50	10	M12x1
CAT40-SF20-80	20	33	40	80	60.9	52	10	M16x1
CAT40-SF25-100	25	44	50	100	80.9	58	10	M16x1
CAT40-SF32-100	32	44	50	100	80.9	62	10	M16x1
CAT40-SF06-120	6	21	27	120	100.9	36	10	M5
CAT40-SF08-120	8	21	27	120	100.9	36	10	M6
CAT40-SF10-120	10	24	32	120	100.9	42	10	M8x1
CAT40-SF12-120	12	24	32	120	100.9	47	10	M10x1
CAT40-SF14-120	14	27	34	120	100.9	47	10	M10x1
CAT40-SF16-120	16	27	34	120	100.9	50	10	M12x1
CAT40-SF18-120	18	33	42	120	100.9	50	10	M12x1
CAT40-SF20-120	20	33	42	120	100.9	52	10	M16x1
CAT40-SF25-120	25	44	50	120	100.9	58	10	M16x1
CAT40-SF06-160	6	21	32	160	140.9	36	10	M5
CAT40-SF08-160	8	21	32	160	140.9	36	10	M6
CAT40-SF10-160	10	24	34	160	140.9	42	10	M8x1
CAT40-SF12-160	12	24	34	160	140.9	47	10	M10x1
CAT40-SF14-160	14	27	42	160	140.9	47	10	M10x1
CAT40-SF16-160	16	27	42	160	140.9	50	10	M12x1
CAT40-SF18-160	18	33	50	160	140.9	50	10	M12x1
CAT40-SF20-160	20	33	50	160	140.9	52	10	M16x1
CAT40-SF25-160	25	44	50	160	140.9	58	10	M16x1
CAT40-SF32-160	32	44	50	160	140.9	62	10	M16x1

Shrink Fit Chuck, 4.5°, Standard
热缩刀柄, 标准型

A ↗ ≤0.003	RPM G2.5/25000	AD
---------------	-------------------	----

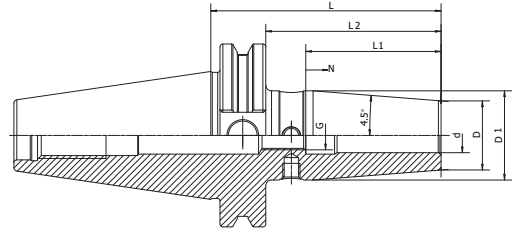

Size	d	D	D1	L	L2	L1	N	G
CAT40-SF06-200	6	21	32	200	180.9	36	10	M5
CAT40-SF08-200	8	21	32	200	180.9	36	10	M6
CAT40-SF10-200	10	24	34	200	180.9	42	10	M8x1
CAT40-SF12-200	12	24	34	200	180.9	47	10	M10x1
CAT40-SF14-200	14	27	42	200	180.9	47	10	M10x1
CAT40-SF16-200	16	27	42	200	180.9	50	10	M12x1
CAT40-SF18-200	18	33	50	200	180.9	50	10	M12x1
CAT40-SF20-200	20	33	50	200	180.9	52	10	M16x1
CAT40-SF25-200	25	44	50	200	180.9	58	10	M16x1
CAT40-SF32-200	32	44	50	200	180.9	62	10	M16x1
CAT50-SF06-80	6	21	27	80	60.9	36	10	M5
CAT50-SF08-80	8	21	27	80	60.9	36	10	M6
CAT50-SF10-80	10	24	31	80	60.9	42	10	M8x1
CAT50-SF12-80	12	24	31	80	60.9	47	10	M10x1
CAT50-SF14-80	14	27	34	80	60.9	47	10	M10x1
CAT50-SF16-80	16	27	34	80	60.9	50	10	M12x1
CAT50-SF18-80	18	33	40	80	60.9	50	10	M12x1
CAT50-SF20-80	20	33	39.5	80	60.9	52	10	M16x1
CAT50-SF25-100	25	44	52.5	100	80.9	58	10	M16x1
CAT50-SF32-100	32	44	52.5	100	80.9	62	10	M16x1
CAT50-SF06-120	6	21	27	120	100.9	36	10	M5
CAT50-SF08-120	8	21	27	120	100.9	36	10	M6
CAT50-SF10-120	10	24	32	120	100.9	42	10	M8x1
CAT50-SF12-120	12	24	32	120	100.9	47	10	M10x1
CAT50-SF14-120	14	27	34	120	100.9	47	10	M10x1
CAT50-SF16-120	16	27	34	120	100.9	50	10	M12x1
CAT50-SF18-120	18	33	42	120	100.9	50	10	M12x1
CAT50-SF20-120	20	33	42	120	100.9	52	10	M16x1
CAT50-SF25-120	25	44	53	120	100.9	58	10	M16x1
CAT50-SF32-120	32	44	53	120	100.9	62	10	M16x1

Shrink Fit Chuck, 4.5°, Standard

热缩刀柄, 标准型

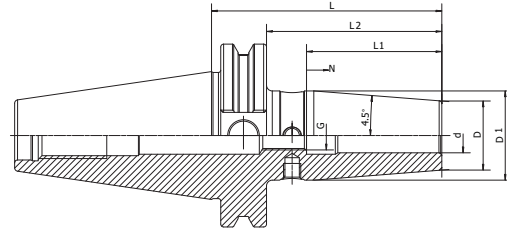
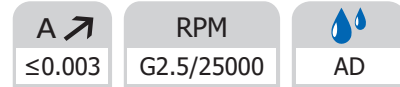

Size	d	D	D1	L	L2	L1	N	G
CAT50-SF06-160	6	21	32	160	140.9	36	10	M5
CAT50-SF08-160	8	21	32	160	140.9	36	10	M6
CAT50-SF10-160	10	24	34	160	140.9	42	10	M8x1
CAT50-SF12-160	12	24	34	160	140.9	47	10	M10x1
CAT50-SF14-160	14	27	42	160	140.9	47	10	M10x1
CAT50-SF16-160	16	27	42	160	140.9	50	10	M12x1
CAT50-SF18-160	18	33	51	160	140.9	50	10	M12x1
CAT50-SF20-160	20	33	51	160	140.9	52	10	M16x1
CAT50-SF25-160	25	44	60	160	140.9	58	10	M16x1
CAT50-SF32-160	32	44	60	160	140.9	62	10	M16x1
CAT50-SF06-200	6	21	32	200	180.9	36	10	M5
CAT50-SF08-200	8	21	32	200	180.9	36	10	M6
CAT50-SF10-200	10	24	34	200	180.9	42	10	M8x1
CAT50-SF12-200	12	24	34	200	180.9	47	10	M10x1
CAT50-SF14-200	14	27	42	200	180.9	47	10	M10x1
CAT50-SF16-200	16	27	42	200	180.9	50	10	M12x1
CAT50-SF18-200	18	33	51	200	180.9	50	10	M12x1
CAT50-SF20-200	20	33	51	200	180.9	52	10	M16x1
CAT50-SF25-200	25	44	60	200	180.9	58	10	M16x1
CAT50-SF32-200	32	44	60	200	180.9	62	10	M16x1

Shrink Fit Chuck, 4.5°, Standard
热缩刀柄, 标准型

A ↗ ≤0.003	RPM G2.5/25000	AD
---------------	-------------------	----

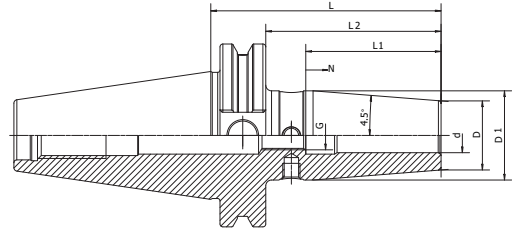

Size	d	D	D1	L	L2	L1	N	G
CAT40-SF1/8-3.15"	0.125"	0.59"	0.79"	3.15"	2.40"	-	-	-
CAT40-SF3/16-3.15"	0.187"	0.59"	0.79"	3.15"	2.40"	-	-	-
CAT40-SF1/4-3.15"	0.250"	0.83"	1.06"	3.15"	2.40"	1.42"	0.39"	M5
CAT40-SF5/16-3.15"	0.312"	0.83"	1.06"	3.15"	2.40"	1.42"	0.39"	M6
CAT40-SF3/8-3.15"	0.375"	0.94"	1.26"	3.15"	2.40"	1.65"	0.39"	M8x1
CAT40-SF1/2-3.15"	0.500"	1.06"	1.34"	3.15"	2.40"	1.85"	0.39"	M10x1
CAT40-SF5/8-3.15"	0.625"	1.06"	1.34"	3.15"	2.40"	1.97"	0.39"	M12x1
CAT40-SF3/4-3.15"	0.750"	1.30"	1.65"	3.15"	2.40"	2.05"	0.39"	M16x1
CAT40-SF1-3.94"	1.000"	1.73"	2.09"	3.94"	2.56"	2.44"	0.39"	M16x1
CAT40-SF1-1/4-3.94"	1.250"	1.73"	2.09"	3.94"	2.56"	2.44"	0.39"	M16x1
CAT40-SF1/8-4.72"	0.125"	0.59"	0.79"	4.72"	3.34"	-	-	-
CAT40-SF3/16-4.72"	0.187"	0.59"	0.79"	4.72"	3.34"	-	-	-
CAT40-SF1/4-4.72"	0.250"	0.83"	1.06"	4.72"	3.34"	1.42"	0.39"	M5
CAT40-SF5/16-4.72"	0.312"	0.83"	1.06"	4.72"	3.34"	1.42"	0.39"	M6
CAT40-SF3/8-4.72"	0.375"	0.94"	1.26"	4.72"	3.34"	1.65"	0.39"	M8x1
CAT40-SF1/2-4.72"	0.500"	1.06"	1.34"	4.72"	3.34"	1.85"	0.39"	M10x1
CAT40-SF5/8-4.72"	0.625"	1.06"	1.34"	4.72"	3.34"	1.97"	0.39"	M12x1
CAT40-SF3/4-4.72"	0.750"	1.30"	1.65"	4.72"	3.34"	2.05"	0.39"	M16x1
CAT40-SF1-4.72"	1.000"	1.73"	2.09"	4.72"	3.34"	2.44"	0.39"	M16x1
CAT40-SF1-1/4-4.72"	1.250"	1.73"	2.09"	4.72"	3.34"	2.44"	0.39"	M16x1
CAT40-SF1/8-6.30"	0.125"	0.59"	0.79"	6.30"	4.92"	-	-	-
CAT40-SF3/16-6.30"	0.187"	0.59"	0.79"	6.30"	4.92"	-	-	-
CAT40-SF1/4-6.30"	0.250"	0.83"	1.26"	6.30"	4.92"	1.42"	0.39"	M5
CAT40-SF5/16-6.30"	0.312"	0.83"	1.26"	6.30"	4.92"	1.42"	0.39"	M6
CAT40-SF3/8-6.30"	0.375"	0.94"	1.34"	6.30"	4.92"	1.65"	0.39"	M8x1
CAT40-SF1/2-6.30"	0.500"	1.06"	1.65"	6.30"	4.92"	1.85"	0.39"	M10x1
CAT40-SF5/8-6.30"	0.625"	1.06"	1.65"	6.30"	4.92"	1.97"	0.39"	M12x1
CAT40-SF3/4-6.30"	0.750"	1.30"	1.75"	6.30"	4.92"	2.05"	0.39"	M16x1
CAT40-SF1-6.30"	1.000"	1.73"	2.09"	6.30"	4.92"	2.44"	0.39"	M16x1
CAT40-SF1-1/4-6.30"	1.250"	1.73"	2.09"	6.30"	4.92"	2.44"	0.39"	M16x1

Shrink Fit Chuck, 4.5°, Standard

热缩刀柄, 标准型

A ↗ ≤0.003	RPM G2.5/25000	AD
---------------	-------------------	----

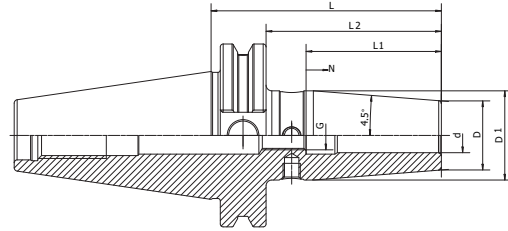

Size	d	D	D1	L	L2	L1	N	G
CAT50-SF1/4-3.15"	0.250"	0.83"	1.06"	3.15"	2.36"	1.42"	0.39"	M5
CAT50-SF3/8-3.15"	0.375"	0.94"	1.26"	3.15"	2.36"	1.65"	0.39"	M8x1
CAT50-SF1/2-3.15"	0.500"	1.06"	1.34"	3.15"	2.36"	1.85"	0.39"	M10x1
CAT50-SF5/8-3.15"	0.625"	1.06"	1.34"	3.15"	2.36"	1.97"	0.39"	M12x1
CAT50-SF3/4-3.15"	0.750"	1.30"	1.65"	3.15"	2.36"	2.05"	0.39"	M16x1
CAT50-SF1-3.94"	1.000"	1.73"	2.09"	3.94"	2.75"	2.44"	0.39"	M16x1
CAT50-SF1-1/4-3.94"	1.250"	1.73"	2.09"	3.94"	2.75"	2.44"	0.39"	M16x1
CAT50-SF1/4-4.72"	0.250"	0.83"	1.06"	4.72"	3.35"	1.42"	0.39"	M5
CAT50-SF3/8-4.72"	0.375"	0.94"	1.26"	4.72"	3.35"	1.65"	0.39"	M8x1
CAT50-SF1/2-4.72"	0.500"	1.06"	1.34"	4.72"	3.35"	1.85"	0.39"	M10x1
CAT50-SF5/8-4.72"	0.625"	1.06"	1.34"	4.72"	3.35"	1.97"	0.39"	M12x1
CAT50-SF3/4-4.72"	0.750"	1.30"	1.65"	4.72"	3.35"	2.05"	0.39"	M16x1
CAT50-SF1-4.72"	1.000"	1.73"	2.09"	4.72"	3.35"	2.44"	0.39"	M16x1
CAT50-SF1-1/4-4.72"	1.250"	1.73"	2.09"	4.72"	3.35"	2.44"	0.39"	M16x1
CAT50-SF1/4-6.30"	0.250"	0.83"	1.26"	6.30"	4.92"	1.42"	0.39"	M5
CAT50-SF3/8-6.30"	0.375"	0.94"	1.34"	6.30"	4.92"	1.65"	0.39"	M8x1
CAT50-SF1/2-6.30"	0.500"	1.06"	1.65"	6.30"	4.92"	1.85"	0.39"	M10x1
CAT50-SF5/8-6.30"	0.625"	1.06"	1.65"	6.30"	4.92"	1.97"	0.39"	M12x1
CAT50-SF3/4-6.30"	0.750"	1.30"	2.01"	6.30"	4.92"	2.05"	0.39"	M16x1
CAT50-SF1-6.30"	1.000"	1.73"	2.36"	6.30"	4.92"	2.44"	0.39"	M16x1
CAT50-SF1-1/4-6.30"	1.250"	1.73"	2.36"	6.30"	4.92"	2.44"	0.39"	M16x1

Shrink Fit Chuck, 4.5°, Standard
热缩刀柄, 标准型

A ↗ ≤0.003	RPM G2.5/25000	AD
---------------	-------------------	----

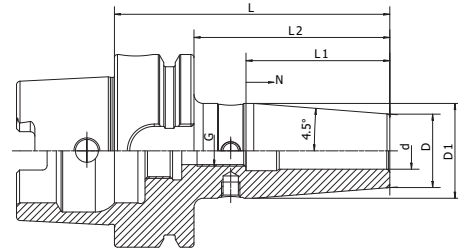

Size	d	D	D1	L	L2	L1	N	G
HSK32A-SF03-65	3	15	20	65	45	-	-	-
HSK32A-SF04-65	4	15	20	65	45	-	-	-
HSK32A-SF05-65	5	15	20	65	45	-	-	-
HSK32A-SF06-75	6	21	26	75	55	36	10	M5
HSK32A-SF08-75	8	21	26	75	55	36	10	M6
HSK32A-SF10-75	10	24	29	75	55	42	10	M8x1
HSK32A-SF12-80	12	24	29	80	60	47	5	M10x1
HSK40A-SF03-60	3	15	20	60	40	-	-	-
HSK40A-SF04-60	4	15	20	60	40	-	-	-
HSK40A-SF05-60	5	15	20	60	40	-	-	-
HSK40A-SF06-80	6	21	27	80	60	36	10	M5
HSK40A-SF08-80	8	21	27	80	60	36	10	M6
HSK40A-SF10-80	10	24	32	80	60	42	10	M8x1
HSK40A-SF12-90	12	24	32	90	70	47	10	M10x1
HSK40A-SF14-90	14	27	34	90	70	47	10	M10x1
HSK40A-SF16-90	16	27	34	90	70	50	10	M12x1
HSK50A-SF03-80	3	15	20	80	54	-	-	-
HSK50A-SF04-80	4	15	20	80	54	-	-	-
HSK50A-SF05-80	5	15	20	80	54	-	-	-
HSK50A-SF06-80	6	21	27	80	54	36	10	M5
HSK50A-SF08-80	8	21	27	80	54	36	10	M6
HSK50A-SF10-85	10	24	32	85	59	42	10	M8x1
HSK50A-SF12-90	12	24	32	90	64	47	10	M10x1
HSK50A-SF14-90	14	27	34	90	64	47	10	M10x1
HSK50A-SF16-95	16	27	34	95	69	50	10	M12x1
HSK50A-SF18-95	18	33	42	95	69	50	10	M12x1
HSK50A-SF20-100	20	33	42	100	74	52	10	M16x1

Shrink Fit Chuck, 4.5°, Standard

热缩刀柄, 标准型

A ↗ ≤0.003	RPM G2.5/25000	AD
---------------	-------------------	----

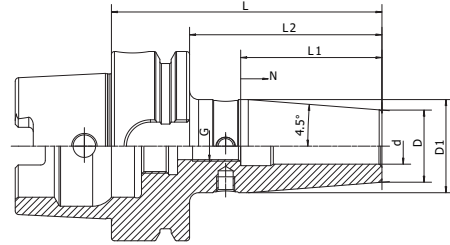

Size	d	D	D1	L	L2	L1	N	G
HSK63A-SF03-80	3	15	20	80	54	-	-	-
HSK63A-SF04-80	4	15	20	80	54	-	-	-
HSK63A-SF05-80	5	15	20	80	54	-	-	-
HSK63A-SF06-80	6	21	26.5	80	54	36	10	M5
HSK63A-SF08-80	8	21	26.5	80	54	36	10	M6
HSK63A-SF10-85	10	24	30.5	85	59	42	10	M8x1
HSK63A-SF12-90	12	24	31	90	64	47	10	M10x1
HSK63A-SF14-90	14	27	34	90	64	47	10	M10x1
HSK63A-SF16-95	16	27	34	95	69	50	10	M12x1
HSK63A-SF18-95	18	33	41	95	69	50	10	M12x1
HSK63A-SF20-100	20	33	42	100	74	52	10	M16x1
HSK63A-SF25-115	25	44	52.5	115	89	58	10	M16x1
HSK63A-SF32-120	32	44	52.5	120	94	62	10	M16x1
HSK63A-SF03-120	3	15	20	120	94	-	-	-
HSK63A-SF04-120	4	15	20	120	94	-	-	-
HSK63A-SF05-120	5	15	20	120	94	-	-	-
HSK63A-SF06-120	6	21	27	120	94	36	10	M5
HSK63A-SF08-120	8	21	27	120	94	36	10	M6
HSK63A-SF10-120	10	24	32	120	94	42	10	M8x1
HSK63A-SF12-120	12	24	32	120	94	47	10	M10x1
HSK63A-SF14-120	14	27	34	120	94	47	10	M10x1
HSK63A-SF16-120	16	27	34	120	94	50	10	M12x1
HSK63A-SF18-120	18	33	42	120	94	50	10	M12x1
HSK63A-SF20-120	20	33	42	120	94	52	10	M16x1
HSK63A-SF25-120	25	44	52.5	120	94	58	10	M16x1

Shrink Fit Chuck, 4.5°, Standard
热缩刀柄, 标准型

A ↗ ≤0.003	RPM G2.5/25000	AD
---------------	-------------------	----

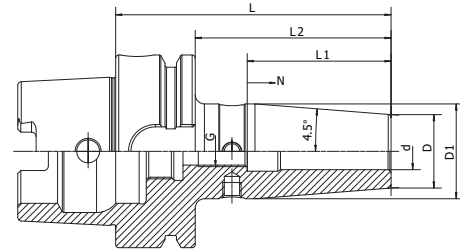

Size	d	D	D1	L	L2	L1	N	G
HSK63A-SF03-160	3	15	25	160	134	-	-	-
HSK63A-SF04-160	4	15	25	160	134	-	-	-
HSK63A-SF05-160	5	15	25	160	134	-	-	-
HSK63A-SF06-160	6	21	32	160	134	36	10	M5
HSK63A-SF08-160	8	21	32	160	134	36	10	M6
HSK63A-SF10-160	10	24	34	160	134	42	10	M8x1
HSK63A-SF12-160	12	24	34	160	134	47	10	M10x1
HSK63A-SF14-160	14	27	42	160	134	47	10	M10x1
HSK63A-SF16-160	16	27	42	160	134	50	10	M12x1
HSK63A-SF18-160	18	33	51	160	134	50	10	M12x1
HSK63A-SF20-160	20	33	51	160	134	52	10	M16x1
HSK63A-SF25-160	25	44	52.5	160	134	58	10	M16x1
HSK63A-SF32-160	32	44	52.5	160	134	62	10	M16x1
HSK63A-SF06-200	6	21	32	200	174	36	10	M5
HSK63A-SF08-200	8	21	32	200	174	36	10	M6
HSK63A-SF10-200	10	24	34	200	174	42	10	M8x1
HSK63A-SF12-200	12	24	34	200	174	47	10	M10x1
HSK63A-SF14-200	14	27	42	200	174	47	10	M10x1
HSK63A-SF16-200	16	27	42	200	174	50	10	M12x1
HSK63A-SF18-200	18	33	51	200	174	50	10	M12x1
HSK63A-SF20-200	20	33	51	200	174	52	10	M16x1
HSK63A-SF25-200	25	44	52.5	200	174	58	10	M16x1
HSK63A-SF32-200	32	44	52.5	200	174	62	10	M16x1

Shrink Fit Chuck, 4.5°, Standard

热缩刀柄, 标准型

 A ↗
 ≤0.003

 RPM
 G2.5/25000

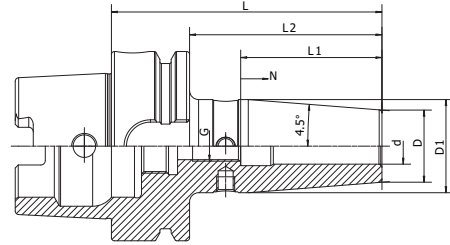
 AD

Size	d	D	D1	L	L2	L1	N	G
HSK63A-SF06-250	6	21	32	250	224	36	10	M5
HSK63A-SF08-250	8	21	32	250	224	36	10	M6
HSK63A-SF10-250	10	24	34	250	224	42	10	M8x1
HSK63A-SF12-250	12	24	34	250	224	47	10	M10x1
HSK63A-SF14-250	14	27	42	250	224	47	10	M10x1
HSK63A-SF16-250	16	27	42	250	224	50	10	M12x1
HSK63A-SF18-250	18	33	51	250	224	50	10	M12x1
HSK63A-SF20-250	20	33	51	250	224	52	10	M16x1
HSK63A-SF25-250	25	44	52.5	250	224	58	10	M16x1
HSK63A-SF32-250	32	44	52.5	250	224	62	10	M16x1
HSK63A-SF06-300	6	21	32	300	274	36	10	M5
HSK63A-SF08-300	8	21	32	300	274	36	10	M6
HSK63A-SF10-300	10	24	34	300	274	42	10	M8x1
HSK63A-SF12-300	12	24	34	300	274	47	10	M10x1
HSK63A-SF14-300	14	27	42	300	274	47	10	M10x1
HSK63A-SF16-300	16	27	42	300	274	50	10	M12x1
HSK63A-SF18-300	18	33	51	300	274	50	10	M12x1
HSK63A-SF20-300	20	33	51	300	274	52	10	M16x1
HSK63A-SF25-300	25	44	52.5	300	274	58	10	M16x1
HSK63A-SF32-300	32	44	52.5	300	274	62	10	M16x1

Shrink Fit Chuck, 4.5°, Standard 热缩刀柄, 标准型

A ↗ ≤0.003	RPM G2.5/25000	AD
---------------	-------------------	----

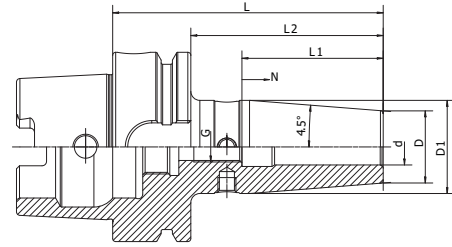

Size	d	D	D1	L	L2	L1	N	G
HSK80A-SF06-85	6	21	27	85	59	36	10	M5
HSK80A-SF08-85	8	21	27	85	59	36	10	M6
HSK80A-SF10-90	10	24	32	90	64	42	10	M8x1
HSK80A-SF12-95	12	24	32	95	69	47	10	M10x1
HSK80A-SF14-95	14	27	34	95	69	47	10	M10x1
HSK80A-SF16-100	16	27	34	100	74	50	10	M12x1
HSK80A-SF18-100	18	33	42	100	74	50	10	M12x1
HSK80A-SF20-105	20	33	42	105	79	52	10	M16x1
HSK80A-SF25-115	25	44	53	115	89	58	10	M16x1
HSK80A-SF32-120	32	44	53	120	94	62	10	M16x1
HSK100A-SF03-85	3	15	20	85	56	-	-	-
HSK100A-SF04-85	4	15	20	85	56	-	-	-
HSK100A-SF05-85	5	15	20	85	56	-	-	-
HSK100A-SF06-85	6	21	26.5	85	56	36	10	M5
HSK100A-SF08-85	8	21	26.5	85	56	36	10	M6
HSK100A-SF10-90	10	24	30.5	90	61	42	10	M8x1
HSK100A-SF12-95	12	24	31	95	66	47	10	M10x1
HSK100A-SF14-95	14	27	34	95	66	47	10	M10x1
HSK100A-SF16-100	16	27	34	100	71	50	10	M12x1
HSK100A-SF18-100	18	33	41	100	71	50	10	M12x1
HSK100A-SF20-105	20	33	42	105	76	52	10	M16x1
HSK100A-SF25-115	25	44	53	115	86	58	10	M16x1
HSK100A-SF32-120	32	44	53	120	91	62	10	M16x1

Shrink Fit Chuck, 4.5°, Standard

热缩刀柄, 标准型

A ↗ ≤0.003	RPM G2.5/25000	 AD
---------------	-------------------	--------

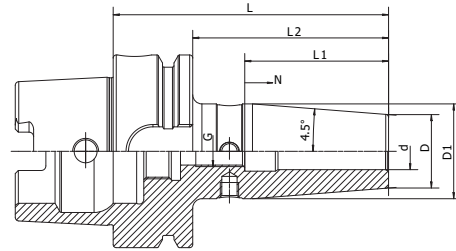

Size	d	D	D1	L	L2	L1	N	G
HSK100A-SF06-120	6	21	27	120	91	36	10	M5
HSK100A-SF08-120	8	21	27	120	91	36	10	M6
HSK100A-SF10-120	10	24	32	120	91	42	10	M8x1
HSK100A-SF12-120	12	24	32	120	91	47	10	M10x1
HSK100A-SF14-120	14	27	34	120	91	47	10	M10x1
HSK100A-SF16-120	16	27	34	120	91	50	10	M12x1
HSK100A-SF18-120	18	33	42	120	91	50	10	M12x1
HSK100A-SF20-120	20	33	42	120	91	52	10	M16x1
HSK100A-SF25-120	25	44	53	120	91	58	10	M16x1
HSK100A-SF06-160	6	21	32	160	131	36	10	M5
HSK100A-SF08-160	8	21	32	160	131	36	10	M6
HSK100A-SF10-160	10	24	34	160	131	42	10	M8x1
HSK100A-SF12-160	12	24	34	160	131	47	10	M10x1
HSK100A-SF14-160	14	27	42	160	131	47	10	M10x1
HSK100A-SF16-160	16	27	42	160	131	50	10	M12x1
HSK100A-SF18-160	18	33	50.5	160	131	50	10	M12x1
HSK100A-SF20-160	20	33	50.5	160	131	52	10	M16x1
HSK100A-SF25-160	25	44	60	160	131	58	10	M16x1
HSK100A-SF32-160	32	44	60	160	131	62	10	M16x1
HSK100A-SF06-200	6	21	32	200	171	36	10	M5
HSK100A-SF08-200	8	21	32	200	171	36	10	M6
HSK100A-SF10-200	10	24	34	200	171	42	10	M8x1
HSK100A-SF12-200	12	24	34	200	171	47	10	M10x1
HSK100A-SF14-200	14	27	42	200	171	47	10	M10x1
HSK100A-SF16-200	16	27	42	200	171	50	10	M12x1
HSK100A-SF18-200	18	33	51	200	171	50	10	M12x1
HSK100A-SF20-200	20	33	51	200	171	52	10	M16x1
HSK100A-SF25-200	25	44	60	200	171	58	10	M16x1
HSK100A-SF32-200	32	44	60	200	171	62	10	M16x1

Shrink Fit Chuck, 4.5°, Standard
热缩刀柄, 标准型

A ↗ ≤0.003	RPM G2.5/25000	 AD
---------------	-------------------	--------

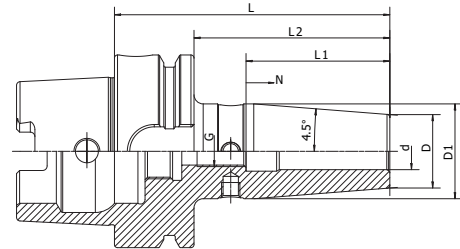

Size	d	D	D1	L	L2	L1	N	G
HSK100A-SF06-250	6	21	32	250	221	36	10	M5
HSK100A-SF08-250	8	21	32	250	221	36	10	M6
HSK100A-SF10-250	10	24	34	250	221	42	10	M8x1
HSK100A-SF12-250	12	24	34	250	221	47	10	M10x1
HSK100A-SF14-250	14	27	42	250	221	47	10	M10x1
HSK100A-SF16-250	16	27	42	250	221	50	10	M12x1
HSK100A-SF18-250	18	33	51	250	221	50	10	M12x1
HSK100A-SF20-250	20	33	51	250	221	52	10	M16x1
HSK100A-SF25-250	25	44	60	250	221	58	10	M16x1
HSK100A-SF32-250	32	44	60	250	221	62	10	M16x1
HSK100A-SF06-300	6	21	32	300	271	36	10	M5
HSK100A-SF08-300	8	21	32	300	271	36	10	M6
HSK100A-SF10-300	10	24	34	300	271	42	10	M8x1
HSK100A-SF12-300	12	24	34	300	271	47	10	M10x1
HSK100A-SF14-300	14	27	42	300	271	47	10	M10x1
HSK100A-SF16-300	16	27	42	300	271	50	10	M12x1
HSK100A-SF18-300	18	33	51	300	271	50	10	M12x1
HSK100A-SF20-300	20	33	51	300	271	52	10	M16x1
HSK100A-SF25-300	25	44	60	300	271	58	10	M16x1
HSK100A-SF32-300	32	44	60	300	271	62	10	M16x1

Shrink Fit Chuck, 4.5°, Standard

热缩刀柄, 标准型

A ↗ ≤0.003	RPM G2.5/25000	AD
---------------	-------------------	----

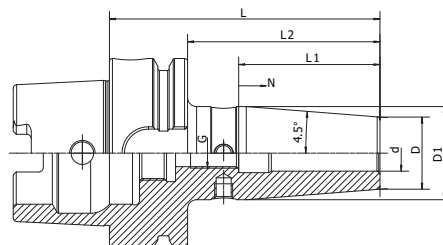

Size	d	D	D1	L	L2	L1	N	G
HSK63A-SF1/8-3.15"	0.125"	0.59"	0.79"	3.15"	2.13"	-	-	-
HSK63A-SF3/16-3.15"	0.187"	0.59"	0.79"	3.15"	2.13"	-	-	-
HSK63A-SF1/4-3.15"	0.250"	0.83"	1.06"	3.15"	2.13"	1.42"	0.39"	M5
HSK63A-SF5/16-3.15"	0.312"	0.83"	1.06"	3.15"	2.13"	1.42"	0.39"	M6
HSK63A-SF3/8-3.35"	0.375"	0.94"	1.26"	3.35"	2.32"	1.65"	0.39"	M8x1
HSK63A-SF1/2-3.54"	0.500"	1.06"	1.34"	3.54"	2.52"	1.85"	0.39"	M10x1
HSK63A-SF5/8-3.74"	0.625"	1.06"	1.34"	3.74"	2.72"	1.97"	0.39"	M12x1
HSK63A-SF3/4-3.94"	0.750"	1.30"	1.65"	3.94"	2.91"	2.05"	0.39"	M16x1
HSK63A-SF1-4.53"	1.000"	1.73"	2.07"	4.53"	3.50"	2.44"	0.39"	M16x1
HSK63A-SF1/8-4.72"	0.125"	0.59"	0.79"	4.72"	3.70"	-	-	-
HSK63A-SF3/16-4.72"	0.187"	0.59"	0.79"	4.72"	3.70"	-	-	-
HSK63A-SF1/4-4.72"	0.250"	0.83"	1.06"	4.72"	3.70"	1.42"	0.39"	M5
HSK63A-SF5/16-4.72"	0.312"	0.83"	1.06"	4.72"	3.70"	1.42"	0.39"	M6
HSK63A-SF3/8-4.72"	0.375"	0.94"	1.26"	4.72"	3.70"	1.65"	0.39"	M8x1
HSK63A-SF1/2-4.72"	0.500"	1.06"	1.34"	4.72"	3.70"	1.85"	0.39"	M10x1
HSK63A-SF5/8-4.72"	0.625"	1.06"	1.34"	4.72"	3.70"	1.97"	0.39"	M12x1
HSK63A-SF3/4-4.72"	0.750"	1.30"	1.65"	4.72"	3.70"	2.05"	0.39"	M16x1
HSK63A-SF1-4.72"	1.000"	1.73"	2.07"	4.72"	3.70"	2.44"	0.39"	M16x1
HSK63A-SF1-1/4-4.72"	1.250"	1.73"	2.07"	4.72"	3.70"	2.44"	0.39"	M16x1
HSK63A-SF1/8-6.3"	0.125"	0.59"	1.06"	6.30"	5.28"	-	-	-
HSK63A-SF3/16-6.3"	0.187"	0.59"	1.06"	6.30"	5.28"	-	-	-
HSK63A-SF1/4-6.3"	0.250"	0.83"	1.26"	6.30"	5.28"	1.42"	0.39"	M5
HSK63A-SF5/16-6.3"	0.312"	0.83"	1.26"	6.30"	5.28"	1.42"	0.39"	M6
HSK63A-SF3/8-6.3"	0.375"	0.94"	1.34"	6.30"	5.28"	1.65"	0.39"	M8x1
HSK63A-SF1/2-6.3"	0.500"	1.06"	1.65"	6.30"	5.28"	1.85"	0.39"	M10x1
HSK63A-SF5/8-6.3"	0.625"	1.06"	1.65"	6.30"	5.28"	1.97"	0.39"	M12x1
HSK63A-SF3/4-6.3"	0.750"	1.30"	2.01"	6.30"	5.28"	2.05"	0.39"	M16x1
HSK63A-SF1-6.3"	1.000"	1.73"	2.07"	6.30"	5.28"	2.44"	0.39"	M16x1
HSK63A-SF1-1/4-6.3"	1.250"	1.73"	2.07"	6.30"	5.28"	2.44"	0.39"	M16x1

Shrink Fit Chuck, 4.5°, Standard
热缩刀柄, 标准型

A ↗ ≤0.003	RPM G2.5/25000	AD
---------------	-------------------	----

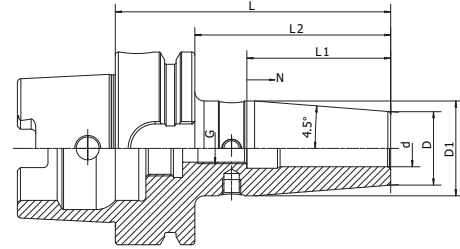

Size	d	D	D1	L	L2	L1	N	G
HSK80A-SF1/4-3.35"	0.250"	0.83"	1.06"	3.35"	2.32"	1.42"	0.39"	M5
HSK80A-SF3/8-3.54"	0.375"	0.94"	1.26"	3.54"	2.52"	1.65"	0.39"	M8x1
HSK80A-SF1/2-3.74"	0.500"	1.06"	1.34"	3.74"	2.72"	1.85"	0.39"	M10x1
HSK80A-SF5/8-3.94"	0.625"	1.06"	1.34"	3.94"	2.91"	1.97"	0.39"	M12x1
HSK80A-SF3/4-4.13"	0.750"	1.30"	1.65"	4.13"	3.11"	2.05"	0.39"	M16x1
HSK80A-SF1-4.53"	1.000"	1.73"	2.09"	4.53"	3.50"	2.44"	0.39"	M16x1
HSK80A-SF1-1/4-4.72"	1.250"	1.73"	2.09"	4.72"	3.70"	2.44"	0.39"	M16x1
HSK100A-SF1/4-3.35"	0.250"	0.83"	1.06"	3.35"	2.20"	1.42"	0.39"	M5
HSK100A-SF3/8-3.54"	0.375"	0.94"	1.26"	3.54"	2.40"	1.65"	0.39"	M8x1
HSK100A-SF1/2-3.74"	0.500"	1.06"	1.34"	3.74"	2.60"	1.85"	0.39"	M10x1
HSK100A-SF5/8-3.94"	0.625"	1.06"	1.34"	3.94"	2.80"	1.97"	0.39"	M12x1
HSK100A-SF3/4-4.13"	0.750"	1.30"	1.65"	4.13"	2.99"	2.05"	0.39"	M16x1
HSK100A-SF1-4.53"	1.000"	1.73"	2.09"	4.53"	3.39"	2.44"	0.39"	M16x1
HSK100A-SF1/4-4.72"	0.250"	0.83"	1.06"	4.72"	3.58"	1.42"	0.39"	M5
HSK100A-SF3/8-4.72"	0.375"	0.94"	1.26"	4.72"	3.58"	1.65"	0.39"	M8x1
HSK100A-SF1/2-4.72"	0.500"	1.06"	1.34"	4.72"	3.58"	1.85"	0.39"	M10x1
HSK100A-SF5/8-4.72"	0.625"	1.06"	1.34"	4.72"	3.58"	1.97"	0.39"	M12x1
HSK100A-SF3/4-4.72"	0.750"	1.30"	1.65"	4.72"	3.58"	2.05"	0.39"	M16x1
HSK100A-SF1-4.72"	1.000"	1.73"	2.09"	4.72"	3.58"	2.44"	0.39"	M16x1
HSK100A-SF1-1/4-4.72"	1.250"	1.73"	2.09"	4.72"	3.58"	2.44"	0.39"	M16x1
HSK100A-SF1/4-6.30"	0.250"	0.83"	1.26"	6.30"	5.16"	1.42"	0.39"	M5
HSK100A-SF3/8-6.30"	0.375"	0.94"	1.34"	6.30"	5.16"	1.65"	0.39"	M8x1
HSK100A-SF1/2-6.30"	0.500"	1.06"	1.65"	6.30"	5.16"	1.85"	0.39"	M10x1
HSK100A-SF5/8-6.30"	0.625"	1.06"	1.65"	6.30"	5.16"	1.97"	0.39"	M12x1
HSK100A-SF3/4-6.30"	0.750"	1.30"	2.01"	6.30"	5.16"	2.05"	0.39"	M16x1
HSK100A-SF1-6.30"	1.000"	1.73"	2.36"	6.30"	5.16"	2.44"	0.39"	M16x1
HSK100A-SF1-1/4-6.30"	1.250"	1.73"	2.36"	6.30"	5.16"	2.44"	0.39"	M16x1

Shrink Fit Chuck, 4.5°, Standard

热缩刀柄, 标准型

A ↗ ≤0.003	RPM G2.5/25000	AD
---------------	-------------------	----

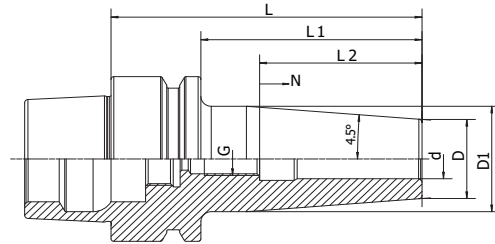

Size	d	D	D1	L	L2	L1	N	G
HSK25E-SF06-50	6	15	19	50	40	36	5	M5
HSK32E-SF03-60	3	15	20	60	40	-	-	-
HSK32E-SF04-60	4	15	20	60	40	-	-	-
HSK32E-SF05-60	5	15	20	60	40	-	-	-
HSK32E-SF06-70	6	20	26	70	50	36	10	M5
HSK32E-SF08-70	8	20	26	70	50	36	10	M6
HSK32E-SF10-70	10	24	29	70	50	42	10	M8x1
HSK32E-SF12-70	12	24	29	70	50	47	10	M10x1
HSK40E-SF03-60	3	15	20	60	40	-	-	-
HSK40E-SF04-60	4	15	20	60	40	-	-	-
HSK40E-SF05-60	5	15	20	60	40	-	-	-
HSK40E-SF06-65	6	21	27	65	45	36	10	M5
HSK40E-SF08-65	8	21	27	65	45	36	10	M6
HSK40E-SF10-65	10	24	30	65	45	42	10	M8x1
HSK40E-SF12-65	12	24	30	65	45	47	10	M10x1
HSK40E-SF03-80	3	15	20	80	60	-	-	-
HSK40E-SF04-80	4	15	20	80	60	-	-	-
HSK40E-SF05-80	5	15	20	80	60	-	-	-
HSK40E-SF06-80	6	21	27	80	60	36	10	M5
HSK40E-SF08-80	8	21	27	80	60	36	10	M6
HSK40E-SF10-80	10	24	32	80	60	42	10	M8x1
HSK40E-SF12-90	12	24	32	90	70	47	10	M10x1
HSK40E-SF16-90	16	27	34	90	70	50	10	M12x1
HSK40E-SF03-120	3	15	20	120	100	-	-	-
HSK40E-SF04-120	4	15	20	120	100	-	-	-
HSK40E-SF05-120	5	15	20	120	100	-	-	-
HSK40E-SF06-120	6	21	27	120	100	36	10	M5
HSK40E-SF08-120	8	21	27	120	100	36	10	M6
HSK40E-SF10-120	10	24	32	120	100	42	10	M8x1
HSK40E-SF12-120	12	24	32	120	100	47	10	M10x1

Shrink Fit Chuck, 4.5°, Standard
热缩刀柄, 标准型



A ↗ ≤0.003	RPM G2.5/25000	AD
---------------	-------------------	----

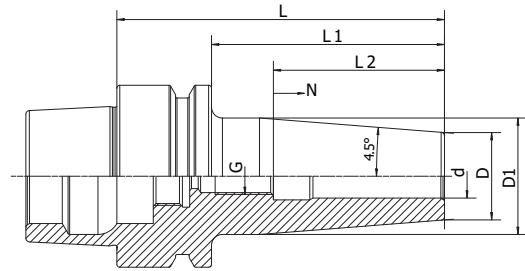

Size	d	D	D1	L	L2	L1	N	G
HSK50E-SF03-80	3	15	20	80	54	-	-	-
HSK50E-SF04-80	4	15	20	80	54	-	-	-
HSK50E-SF05-80	5	15	20	80	54	-	-	-
HSK50E-SF06-80	6	21	27	80	54	36	10	M5
HSK50E-SF08-80	8	21	27	80	54	36	10	M6
HSK50E-SF10-85	10	24	32	85	59	42	10	M8x1
HSK50E-SF12-90	12	24	32	90	64	47	10	M10x1
HSK50E-SF14-90	14	27	34	90	64	47	10	M10x1
HSK50E-SF16-95	16	27	34	95	69	50	10	M12x1
HSK50E-SF18-95	18	33	41	95	69	50	10	M12x1
HSK50E-SF20-100	20	33	41	100	74	52	10	M16x1
HSK63E-SF06-90	6	21	27	90	64	36	10	M5
HSK63E-SF08-90	8	21	27	90	64	36	10	M6
HSK63E-SF10-90	10	24	32	90	64	42	10	M8x1
HSK63E-SF12-90	12	24	32	90	64	47	10	M10x1
HSK63E-SF14-90	14	27	34	90	64	47	10	M10x1
HSK63E-SF16-95	16	27	34	95	69	50	10	M12x1
HSK63E-SF18-95	18	33	42	95	69	50	10	M12x1
HSK63E-SF20-100	20	33	42	100	74	52	10	M16x1
HSK63E-SF25-115	25	44	53	115	89	58	10	M16x1

Inch

Size	d	D	D1	L	L2	L1	N	G
HSK40E-SF1/8"-3.54"	1/8"	0.36"	0.47"	3.54"	2.76"	0.79"	-	-
HSK40E-SF3/16"-3.54"	3/16"	0.63"	0.71"	3.54"	2.76"	0.79"	-	-
HSK40E-SF1/4"-3.54"	1/4"	0.71"	1.06"	3.54"	2.76"	1.42"	0.39"	M5 x 0.8P
HSK40E-SF5/16"-3.54"	5/16"	0.83"	1.06"	3.54"	2.76"	1.42"	0.39"	M6 x 1.0P
HSK40E-SF3/8"-3.54"	3/8"	0.94"	1.26"	3.54"	2.76"	1.65"	0.39"	M8 x 1.25P

Shrink Fit Chuck, 4.5°, Standard

热缩刀柄, 标准型



A ↗ ≤0.003	RPM G2.5/25000	AD
---------------	-------------------	----

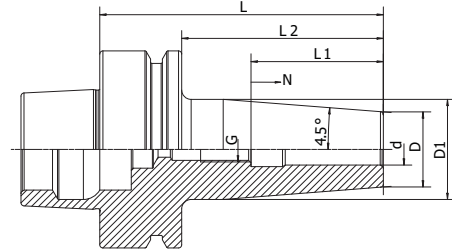

Size	d	D	D1	L	L2	L1	N	G
HSK40F-SF03-60	3	15	20	60	40	-	-	-
HSK40F-SF04-60	4	15	20	60	40	-	-	-
HSK40F-SF05-60	5	15	20	60	40	-	-	-
HSK40F-SF06-65	6	21	27	65	45	36	5	M5
HSK40F-SF08-65	8	21	27	65	45	36	5	M6
HSK40F-SF10-65	10	24	31	65	45	42	5	M8x1
HSK40F-SF12-65	12	24	31	65	45	42	5	M10x1
HSK40F-SF06-80	6	21	27	80	60	36	10	M5
HSK40F-SF08-80	8	21	27	80	60	36	10	M6
HSK40F-SF10-80	10	24	32	80	60	42	10	M8x1
HSK40F-SF12-90	12	24	32	90	70	47	10	M10x1
HSK40F-SF16-90	16	27	34	90	70	50	10	M12x1
HSK63F-SF03-90	3	15	20	90	64	-	-	-
HSK63F-SF04-90	4	15	20	90	54	-	-	-
HSK63F-SF05-90	5	15	20	90	54	-	-	-
HSK63F-SF06-90	6	21	27	90	64	36	10	M5
HSK63F-SF08-90	8	21	27	90	64	36	10	M6
HSK63F-SF10-90	10	24	32	90	64	42	10	M8x1
HSK63F-SF12-90	12	24	32	90	64	47	10	M10x1
HSK63F-SF14-95	14	27	34	95	69	47	10	M10x1
HSK63F-SF16-95	16	27	34	95	69	50	10	M12x1
HSK63F-SF18-95	18	33	42	95	69	50	10	M12x1
HSK63F-SF20-100	20	33	42	100	74	52	10	M16x1
HSK63F-SF25-115	25	36	42	115	89	58	10	M16x1

Shrink Fit Chuck, 4.5°, Standard
热缩刀柄, 标准型

A ↗ ≤0.003	RPM G2.5/25000	AD
---------------	-------------------	----

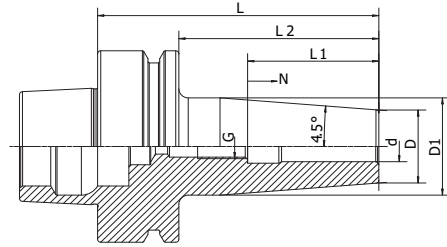

Size	d	D	D1	L	L2	L1	N	G
HSK63F-SF03-120	3	15	20	120	94	-	-	-
HSK63F-SF04-120	4	15	20	120	94	-	-	-
HSK63F-SF05-120	5	15	20	120	94	-	-	-
HSK63F-SF06-120	6	21	27	120	94	36	10	M5
HSK63F-SF08-120	8	21	27	120	94	36	10	M6
HSK63F-SF10-120	10	24	32	120	94	42	10	M8x1
HSK63F-SF12-120	12	24	32	120	94	47	10	M10x1
HSK63F-SF14-120	14	27	34	120	94	47	10	M10x1
HSK63F-SF16-120	16	27	34	120	94	50	10	M12x1
HSK63F-SF18-120	18	33	42	120	94	50	10	M12x1
HSK63F-SF20-120	20	33	42	120	94	52	10	M16x1
HSK63F-SF03-160	3	15	27	160	134	-	-	-
HSK63F-SF04-160	4	15	27	160	134	-	-	-
HSK63F-SF05-160	5	15	27	160	134	-	-	-
HSK63F-SF06-160	6	21	32	160	134	36	10	M5
HSK63F-SF08-160	8	21	32	160	134	36	10	M6
HSK63F-SF10-160	10	24	34	160	134	42	10	M8x1
HSK63F-SF12-160	12	24	34	160	134	47	10	M10x1
HSK63F-SF14-160	14	27	42	160	134	47	10	M10x1
HSK63F-SF16-160	16	27	42	160	134	50	10	M12x1
HSK63F-SF18-160	18	33	51	160	134	50	10	M12x1
HSK63F-SF20-160	20	33	51	160	134	52	10	M16x1

Inch

Size	d	D	D1	L	L2	L1	N	G
HSK63F-SF1/4"-3.54"	1/4"	0.83"	1.06"	3.54	2.52	1.42"		M5
HSK63F-SF5/16"-3.54"	5/16"	0.83"	1.06"	3.54	2.52	1.42"		M6
HSK63F-SF3/8"-3.54"	3/8"	0.94"	1.26"	3.54	2.52	1.65"		M8 x 1
HSK63F-SF1/2"-3.54"	1/2"	1.06"	1.34"	3.54	2.52	1.85"		M10 x 1
HSK63F-SF5/8"-3.74"	5/8"	1.06"	1.34"	3.74"	2.72	1.97"		M12 x 1
HSK63F-SF3/4"-3.94"	3/4"	1.30"	1.65"	3.94"	2.91	2.05"		M16 x 1
HSK63F-SF1.0"-4.53"	1"	1.73"	2.09"	4.53"	3.5	2.44"		M160 x 1

Shrink Fit Chuck, 4.5°, Coolant

热缩刀柄, 端面出水型

A ↗ ≤0.003	RPM G2.5/25000	AD
---------------	-------------------	----

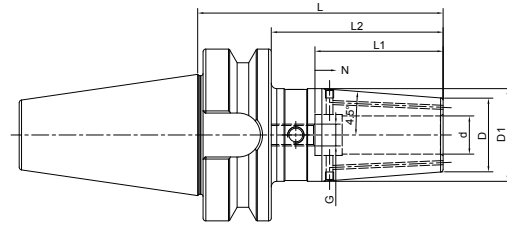

Size	d	D	D1	L	L2	L1	N	G
BT40-SF03-80K	3	15	20	80	53	-	-	-
BT40-SF04-80K	4	15	20	80	53	-	-	-
BT40-SF05-80K	5	15	20	80	53	-	-	-
BT40-SF06-90K	6	21	27	90	63	36	10	M5
BT40-SF08-90K	8	21	27	90	63	36	10	M6
BT40-SF10-90K	10	24	32	90	63	42	10	M8x1
BT40-SF12-90K	12	24	32	90	63	47	10	M10x1
BT40-SF14-90K	14	27	34	90	63	47	10	M10x1
BT40-SF16-90K	16	27	34	90	63	50	10	M12x1
BT40-SF18-90K	18	33	42	90	63	50	10	M12x1
BT40-SF20-90K	20	33	42	90	63	52	10	M16x1
BT40-SF25-100K	25	44	53	100	73	58	10	M16x1
BT40-SF32-100K	32	44	53	100	73	62	10	M16x1
BT40-SF06-120K	6	21	27	120	93	36	10	M5
BT40-SF08-120K	8	21	27	120	93	36	10	M6
BT40-SF10-120K	10	24	32	120	93	42	10	M8x1
BT40-SF12-120K	12	24	32	120	93	47	10	M10x1
BT40-SF14-120K	14	27	34	120	93	47	10	M10x1
BT40-SF16-120K	16	27	34	120	93	50	10	M12x1
BT40-SF18-120K	18	33	42	120	93	50	10	M12x1
BT40-SF20-120K	20	33	42	120	93	52	10	M16x1
BT40-SF25-120K	25	44	53	120	93	58	10	M16x1
BT40-SF32-120K	32	44	53	120	93	62	10	M16x1
BT40-SF06-160K	6	21	32	160	133	36	10	M5
BT40-SF08-160K	8	21	32	160	133	36	10	M6
BT40-SF10-160K	10	24	34	160	133	42	10	M8x1
BT40-SF12-160K	12	24	34	160	133	47	10	M10x1
BT40-SF14-160K	14	27	42	160	133	47	10	M10x1
BT40-SF16-160K	16	27	42	160	133	50	10	M12x1
BT40-SF18-160K	18	33	51	160	133	50	10	M12x1
BT40-SF20-160K	20	33	51	160	133	52	10	M16x1
BT40-SF25-160K	25	44	53	160	133	58	10	M16x1
BT40-SF32-160K	32	44	53	160	133	62	10	M16x1

Shrink Fit Chuck, 4.5°, Coolant
热缩刀柄, 端面出水型

A ↗ ≤0.003	RPM G2.5/25000	AD
---------------	-------------------	----

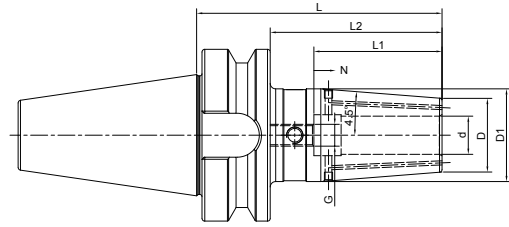

Size	d	D	D1	L	L2	L1	N	G
BT50-SF06-100K	6	21	27	100	62	36	10	M5
BT50-SF08-100K	8	21	27	100	62	36	10	M6
BT50-SF10-100K	10	24	32	100	62	42	10	M8x1
BT50-SF12-100K	12	24	32	100	62	47	10	M10x1
BT50-SF14-100K	14	27	34	100	62	47	10	M10x1
BT50-SF16-100K	16	27	34	100	62	50	10	M12x1
BT50-SF18-100K	18	33	42	100	62	50	10	M12x1
BT50-SF20-100K	20	33	42	100	62	52	10	M16x1
BT50-SF25-110K	25	44	53	110	72	58	10	M16x1
BT50-SF32-110K	32	44	53	110	72	62	10	M16x1
BT50-SF06-120K	6	21	27	120	82	36	10	M5
BT50-SF08-120K	8	21	27	120	82	36	10	M6
BT50-SF10-120K	10	24	32	120	82	42	10	M8x1
BT50-SF12-120K	12	24	32	120	82	47	10	M10x1
BT50-SF14-120K	14	27	34	120	82	47	10	M10x1
BT50-SF16-120K	16	27	34	120	82	50	10	M12x1
BT50-SF18-120K	18	33	42	120	82	50	10	M12x1
BT50-SF20-120K	20	33	42	120	82	52	10	M16x1
BT50-SF25-120K	25	44	53	120	82	58	10	M16x1
BT50-SF32-120K	32	44	53	120	82	62	10	M16x1
BT50-SF06-160K	6	21	32	160	122	36	10	M5
BT50-SF08-160K	8	21	32	160	122	36	10	M6
BT50-SF10-160K	10	24	34	160	122	42	10	M8x1
BT50-SF12-160K	12	24	34	160	122	47	10	M10x1
BT50-SF14-160K	14	27	42	160	122	47	10	M10x1
BT50-SF16-160K	16	27	42	160	122	50	10	M12x1
BT50-SF18-160K	18	33	51	160	122	50	10	M12x1
BT50-SF20-160K	20	33	51	160	122	52	10	M16x1
BT50-SF25-160K	25	44	60	160	122	58	10	M16x1
BT50-SF32-160K	32	44	60	160	122	62	10	M16x1

Shrink Fit Chuck, 4.5°, Coolant 热缩刀柄, 端面出水型

A ↗ ≤0.003	RPM G2.5/25000	AD
---------------	-------------------	----

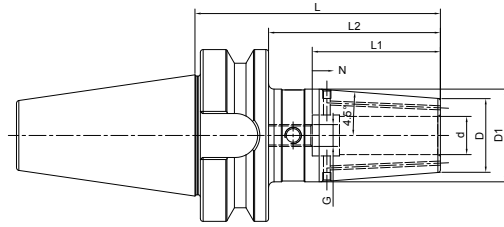

Size	d	D	D1	L	L2	L1	N	G
BBT40-SF03-80K	3	15	20	80	53	-	-	-
BBT40-SF04-80K	4	15	20	80	53	-	-	-
BBT40-SF05-80K	5	15	20	80	53	-	-	-
BBT40-SF06-90K	6	21	27	90	63	36	10	M5
BBT40-SF08-90K	8	21	27	90	63	36	10	M6
BBT40-SF10-90K	10	24	32	90	63	42	10	M8x1
BBT40-SF12-90K	12	24	32	90	63	47	10	M10x1
BBT40-SF14-90K	14	27	34	90	63	47	10	M10x1
BBT40-SF16-90K	16	27	34	90	63	50	10	M12x1
BBT40-SF18-90K	18	33	42	90	63	50	10	M12x1
BBT40-SF20-90K	20	33	42	90	63	52	10	M16x1
BBT40-SF25-100K	25	44	53	100	73	58	10	M16x1
BBT40-SF32-100K	32	44	53	100	73	62	10	M16x1
BBT40-SF06-120K	6	21	27	120	93	36	10	M5
BBT40-SF08-120K	8	21	27	120	93	36	10	M6
BBT40-SF10-120K	10	24	32	120	93	42	10	M8x1
BBT40-SF12-120K	12	24	32	120	93	47	10	M10x1
BBT40-SF14-120K	14	27	34	120	93	47	10	M10x1
BBT40-SF16-120K	16	27	34	120	93	50	10	M12x1
BBT40-SF18-120K	18	33	42	120	93	50	10	M12x1
BBT40-SF20-120K	20	33	42	120	93	52	10	M16x1
BBT40-SF25-120K	25	44	53	120	93	58	10	M16x1
BBT40-SF32-120K	32	44	53	120	93	62	10	M16x1
BBT40-SF06-160K	6	21	32	160	133	36	10	M5
BBT40-SF08-160K	8	21	32	160	133	36	10	M6
BBT40-SF10-160K	10	24	34	160	133	42	10	M8x1
BBT40-SF12-160K	12	24	34	160	133	47	10	M10x1
BBT40-SF14-160K	14	27	42	160	133	47	10	M10x1
BBT40-SF16-160K	16	27	42	160	133	50	10	M12x1
BBT40-SF18-160K	18	33	51	160	133	50	10	M12x1
BBT40-SF20-160K	20	33	51	160	133	52	10	M16x1
BBT40-SF25-160K	25	44	53	160	133	58	10	M16x1
BBT40-SF32-160K	32	44	53	160	133	62	10	M16x1

Shrink Fit Chuck, 4.5°, Coolant
热缩刀柄, 端面出水型

A ↗ ≤0.003	RPM G2.5/25000	AD
---------------	-------------------	----

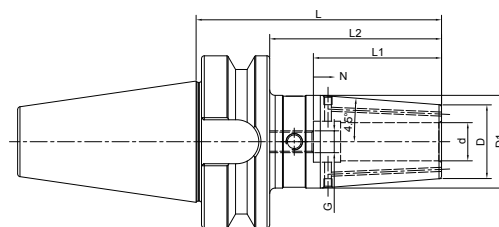

Size	d	D	D1	L	L2	L1	N	G
BBT50-SF06-100K	6	21	27	100	62	36	10	M5
BBT50-SF08-100K	8	21	27	100	62	36	10	M6
BBT50-SF10-100K	10	24	32	100	62	42	10	M8x1
BBT50-SF12-100K	12	24	32	100	62	47	10	M10x1
BBT50-SF14-100K	14	27	34	100	62	47	10	M10x1
BBT50-SF16-100K	16	27	34	100	62	50	10	M12x1
BBT50-SF18-100K	18	33	42	100	62	50	10	M12x1
BBT50-SF20-100K	20	33	42	100	62	52	10	M16x1
BBT50-SF25-110K	25	44	53	110	72	58	10	M16x1
BBT50-SF32-110K	32	44	53	110	72	62	10	M16x1
BBT50-SF06-120K	6	21	27	120	82	36	10	M5
BBT50-SF08-120K	8	21	27	120	82	36	10	M6
BBT50-SF10-120K	10	24	32	120	82	42	10	M8x1
BBT50-SF12-120K	12	24	32	120	82	47	10	M10x1
BBT50-SF14-120K	14	27	34	120	82	47	10	M10x1
BBT50-SF16-120K	16	27	34	120	82	50	10	M12x1
BBT50-SF18-120K	18	33	42	120	82	50	10	M12x1
BBT50-SF20-120K	20	33	42	120	82	52	10	M16x1
BBT50-SF25-120K	25	44	53	120	82	58	10	M16x1
BBT50-SF32-120K	32	44	53	120	82	62	10	M16x1
BBT50-SF06-160K	6	21	32	160	122	36	10	M5
BBT50-SF08-160K	8	21	32	160	122	36	10	M6
BBT50-SF10-160K	10	24	34	160	122	42	10	M8x1
BBT50-SF12-160K	12	24	34	160	122	47	10	M10x1
BBT50-SF14-160K	14	27	42	160	122	47	10	M10x1
BBT50-SF16-160K	16	27	42	160	122	50	10	M12x1
BBT50-SF18-160K	18	33	51	160	122	50	10	M12x1
BBT50-SF20-160K	20	33	51	160	122	52	10	M16x1
BBT50-SF25-160K	25	44	60	160	122	58	10	M16x1
BBT50-SF32-160K	32	44	60	160	122	62	10	M16x1

Shrink Fit Chuck, 4.5°, Coolant 热缩刀柄, 端面出水型

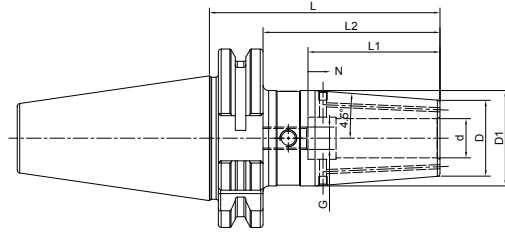
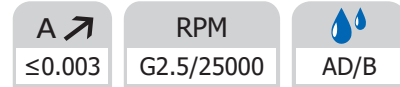

Size	d	D	D1	L	L2	L1	N	G
SK40-SF03-80K	3	15	20	80	60.9	-	-	-
SK40-SF04-80K	4	15	20	80	60.9	-	-	-
SK40-SF05-80K	5	15	20	80	60.9	-	-	-
SK40-SF06-80K	6	21	27	80	60.9	36	10	M5
SK40-SF08-80K	8	21	27	80	60.9	36	10	M6
SK40-SF10-80K	10	24	32	80	60.9	42	10	M8x1
SK40-SF12-80K	12	24	32	80	60.9	47	10	M10x1
SK40-SF14-80K	14	27	34	80	60.9	47	10	M10x1
SK40-SF16-80K	16	27	34	80	60.9	50	10	M12x1
SK40-SF18-80K	18	33	42	80	60.9	50	10	M12x1
SK40-SF20-80K	20	33	42	80	60.9	52	10	M16x1
SK40-SF25-100K	25	44	50	100	80.9	58	10	M16x1
SK40-SF32-100K	32	44	50	100	80.9	62	10	M16x1
SK40-SF06-120K	6	21	27	120	100.9	36	10	M5
SK40-SF08-120K	8	21	27	120	100.9	36	10	M6
SK40-SF10-120K	10	24	32	120	100.9	42	10	M8x1
SK40-SF12-120K	12	24	32	120	100.9	47	10	M10x1
SK40-SF14-120K	14	27	34	120	100.9	47	10	M10x1
SK40-SF16-120K	16	27	34	120	100.9	50	10	M12x1
SK40-SF18-120K	18	33	42	120	100.9	50	10	M12x1
SK40-SF20-120K	20	33	42	120	100.9	52	10	M16x1
SK40-SF06-160K	6	21	32	160	140.9	36	10	M5
SK40-SF08-160K	8	21	32	160	140.9	36	10	M6
SK40-SF10-160K	10	24	34	160	140.9	42	10	M8x1
SK40-SF12-160K	12	24	34	160	140.9	47	10	M10x1
SK40-SF14-160K	14	27	42	160	140.9	47	10	M10x1
SK40-SF16-160K	16	27	42	160	140.9	50	10	M12x1
SK40-SF18-160K	18	33	50	160	140.9	50	10	M12x1
SK40-SF20-160K	20	33	50	160	140.9	52	10	M16x1

Shrink Fit Chuck, 4.5°, Coolant
热缩刀柄, 端面出水型

A ↗ ≤0.003	RPM G2.5/25000	AD
---------------	-------------------	----

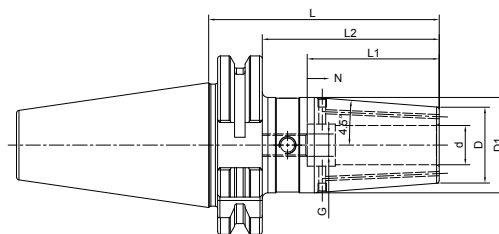

Size	d	D	D1	L	L2	L1	N	G
SK50-SF06-80K	6	21	27	80	60.9	36	10	M5
SK50-SF08-80K	8	21	27	80	60.9	36	10	M6
SK50-SF10-80K	10	24	32	80	60.9	42	10	M8x1
SK50-SF12-80K	12	24	32	80	60.9	47	10	M10x1
SK50-SF14-80K	14	27	34	80	60.9	47	10	M10x1
SK50-SF16-80K	16	27	34	80	60.9	50	10	M12x1
SK50-SF18-80K	18	33	42	80	60.9	50	10	M12x1
SK50-SF20-80K	20	33	42	80	60.9	52	10	M16x1
SK50-SF25-90K	25	44	53	90	70.9	58	10	M16x1
SK50-SF32-90K	32	44	53	90	70.9	62	10	M16x1
SK50-SF06-120K	6	21	27	120	100.9	36	10	M5
SK50-SF08-120K	8	21	27	120	100.9	36	10	M6
SK50-SF10-120K	10	24	32	120	100.9	42	10	M8x1
SK50-SF12-120K	12	24	32	120	100.9	47	10	M10x1
SK50-SF14-120K	14	27	34	120	100.9	47	10	M10x1
SK50-SF16-120K	16	27	34	120	100.9	50	10	M12x1
SK50-SF18-120K	18	33	42	120	100.9	50	10	M12x1
SK50-SF20-120K	20	33	42	120	100.9	52	10	M16x1
SK50-SF25-120K	25	44	53	120	100.9	58	10	M16x1
SK50-SF32-120K	32	44	53	120	100.9	62	10	M16x1
SK50-SF06-160K	6	21	32	160	140.9	36	10	M5
SK50-SF08-160K	8	21	32	160	140.9	36	10	M6
SK50-SF10-160K	10	24	34	160	140.9	42	10	M8x1
SK50-SF12-160K	12	24	34	160	140.9	47	10	M10x1
SK50-SF14-160K	14	27	42	160	140.9	47	10	M10x1
SK50-SF16-160K	16	27	42	160	140.9	50	10	M12x1
SK50-SF18-160K	18	33	51	160	140.9	50	10	M12x1
SK50-SF20-160K	20	33	51	160	140.9	52	10	M16x1
SK50-SF25-160K	25	44	60	160	140.9	58	10	M16x1
SK50-SF32-160K	32	44	60	160	140.9	62	10	M16x1

Shrink Fit Chuck, 4.5°, Coolant 热缩刀柄, 端面出水型

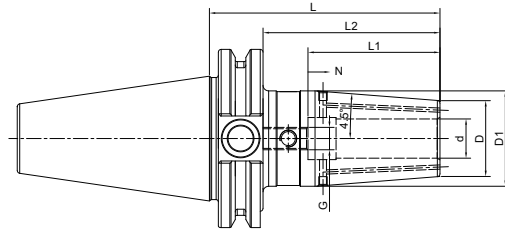
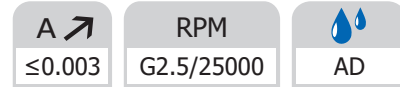

Size	d	D	D1	L	L2	L1	N	G
CAT40-SF03-80K	3	15	20	80	60.9	-	-	-
CAT40-SF04-80K	4	15	20	80	60.9	-	-	-
CAT40-SF05-80K	5	15	20	80	60.9	-	-	-
CAT40-SF06-80K	6	21	27	80	60.9	36	10	M5
CAT40-SF08-80K	8	21	27	80	60.9	36	10	M6
CAT40-SF10-80K	10	24	31	80	60.9	42	10	M8x1
CAT40-SF12-80K	12	24	31	80	60.9	47	10	M10x1
CAT40-SF14-80K	14	27	34	80	60.9	47	10	M10x1
CAT40-SF16-80K	16	27	34	80	60.9	50	10	M12x1
CAT40-SF18-80K	18	33	40	80	60.9	50	10	M12x1
CAT40-SF20-80K	20	33	40	80	60.9	52	10	M16x1
CAT40-SF25-100K	25	44	50	100	80.9	58	10	M16x1
CAT40-SF32-100K	32	44	50	100	80.9	62	10	M16x1
CAT40-SF06-120K	6	21	27	120	100.9	36	10	M5
CAT40-SF08-120K	8	21	27	120	100.9	36	10	M6
CAT40-SF10-120K	10	24	32	120	100.9	42	10	M8x1
CAT40-SF12-120K	12	24	32	120	100.9	47	10	M10x1
CAT40-SF14-120K	14	27	34	120	100.9	47	10	M10x1
CAT40-SF16-120K	16	27	34	120	100.9	50	10	M12x1
CAT40-SF18-120K	18	33	42	120	100.9	50	10	M12x1
CAT40-SF20-120K	20	33	42	120	100.9	52	10	M16x1
CAT40-SF25-120K	25	44	50	120	100.9	58	10	M16x1
CAT40-SF06-160K	6	21	32	160	140.9	36	10	M5
CAT40-SF08-160K	8	21	32	160	140.9	36	10	M6
CAT40-SF10-160K	10	24	34	160	140.9	42	10	M8x1
CAT40-SF12-160K	12	24	34	160	140.9	47	10	M10x1
CAT40-SF14-160K	14	27	42	160	140.9	47	10	M10x1
CAT40-SF16-160K	16	27	42	160	140.9	50	10	M12x1
CAT40-SF18-160K	18	33	50	160	140.9	50	10	M12x1
CAT40-SF20-160K	20	33	50	160	140.9	52	10	M16x1
CAT40-SF25-160K	25	44	50	160	140.9	58	10	M16x1
CAT40-SF32-160K	32	44	50	160	140.9	62	10	M16x1

Shrink Fit Chuck, 4.5°, Coolant
热缩刀柄, 端面出水型

A ↗ ≤0.003	RPM G2.5/25000	AD
---------------	-------------------	----

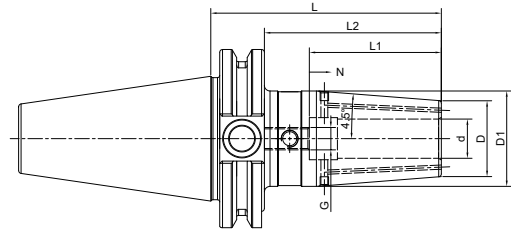

Size	d	D	D1	L	L2	L1	N	G
CAT50-SF06-80K	6	21	27	80	60.9	36	10	M5
CAT50-SF08-80K	8	21	27	80	60.9	36	10	M6
CAT50-SF10-80K	10	24	31	80	60.9	42	10	M8x1
CAT50-SF12-80K	12	24	31	80	60.9	47	10	M10x1
CAT50-SF14-80K	14	27	34	80	60.9	47	10	M10x1
CAT50-SF16-80K	16	27	34	80	60.9	50	10	M12x1
CAT50-SF18-80K	18	33	40	80	60.9	50	10	M12x1
CAT50-SF20-80K	20	33	39.5	80	60.9	52	10	M16x1
CAT50-SF25-100K	25	44	52.5	100	80.9	58	10	M16x1
CAT50-SF32-100K	32	44	52.5	100	80.9	62	10	M16x1
CAT50-SF06-120K	6	21	27	120	100.9	36	10	M5
CAT50-SF08-120K	8	21	27	120	100.9	36	10	M6
CAT50-SF10-120K	10	24	32	120	100.9	42	10	M8x1
CAT50-SF12-120K	12	24	32	120	100.9	47	10	M10x1
CAT50-SF14-120K	14	27	34	120	100.9	47	10	M10x1
CAT50-SF16-120K	16	27	34	120	100.9	50	10	M12x1
CAT50-SF18-120K	18	33	42	120	100.9	50	10	M12x1
CAT50-SF20-120K	20	33	42	120	100.9	52	10	M16x1
CAT50-SF25-120K	25	44	53	120	100.9	58	10	M16x1
CAT50-SF32-120K	32	44	53	120	100.9	62	10	M16x1

Shrink Fit Chuck, 4.5°, Coolant 热缩刀柄, 端面出水型

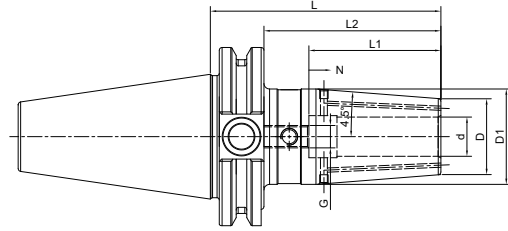
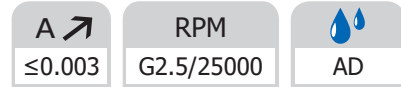

Size	d	D	D1	L	L2	L1	N	G
CAT50-SF06-160K	6	21	32	160	140.9	36	10	M5
CAT50-SF08-160K	8	21	32	160	140.9	36	10	M6
CAT50-SF10-160K	10	24	34	160	140.9	42	10	M8x1
CAT50-SF12-160K	12	24	34	160	140.9	47	10	M10x1
CAT50-SF14-160K	14	27	42	160	140.9	47	10	M10x1
CAT50-SF16-160K	16	27	42	160	140.9	50	10	M12x1
CAT50-SF18-160K	18	33	51	160	140.9	50	10	M12x1
CAT50-SF20-160K	20	33	51	160	140.9	52	10	M16x1
CAT50-SF25-160K	25	44	60	160	140.9	58	10	M16x1
CAT50-SF32-160K	32	44	60	160	140.9	62	10	M16x1
CAT50-SF06-200K	6	21	32	200	180.9	36	10	M5
CAT50-SF08-200K	8	21	32	200	180.9	36	10	M6
CAT50-SF10-200K	10	24	34	200	180.9	42	10	M8x1
CAT50-SF12-200K	12	24	34	200	180.9	47	10	M10x1
CAT50-SF14-200K	14	27	42	200	180.9	47	10	M10x1
CAT50-SF16-200K	16	27	42	200	180.9	50	10	M12x1
CAT50-SF18-200K	18	33	51	200	180.9	50	10	M12x1
CAT50-SF20-200K	20	33	51	200	180.9	52	10	M16x1
CAT50-SF25-200K	25	44	60	200	180.9	58	10	M16x1
CAT50-SF32-200K	32	44	60	200	180.9	62	10	M16x1

Shrink Fit Chuck, 4.5°, Coolant
热缩刀柄, 端面出水型

A ↗ ≤0.003	RPM G2.5/25000	AD
---------------	-------------------	----

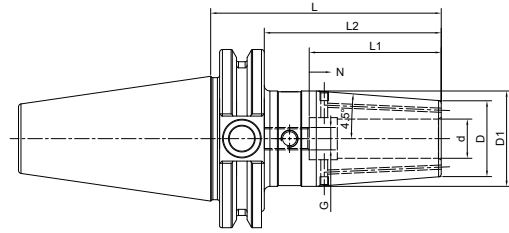

Size	d	D	D1	L	L2	L1	N	G
CAT40-SF1/8-3.15"K	0.125"	0.59"	0.79"	3.15"	2.40"	-	-	-
CAT40-SF3/16-3.15"K	0.187"	0.59"	0.79"	3.15"	2.40"	-	-	-
CAT40-SF1/4-3.15"K	0.250"	0.83"	1.06"	3.15"	2.40"	1.42"	0.39"	M5
CAT40-SF5/16-3.15"K	0.312"	0.83"	1.06"	3.15"	2.40"	1.42"	0.39"	M6
CAT40-SF3/8-3.15"K	0.375"	0.94"	1.26"	3.15"	2.40"	1.65"	0.39"	M8x1
CAT40-SF1/2-3.15"K	0.500"	1.06"	1.34"	3.15"	2.40"	1.85"	0.39"	M10x1
CAT40-SF5/8-3.15"K	0.625"	1.06"	1.34"	3.15"	2.40"	1.97"	0.39"	M12x1
CAT40-SF3/4-3.15"K	0.750"	1.30"	1.65"	3.15"	2.40"	2.05"	0.39"	M16x1
CAT40-SF1-3.94"K	1.000"	1.73"	2.09"	3.94"	2.56"	2.44"	0.39"	M16x1
CAT40-SF1-1/4-3.94"K	1.250"	1.73"	2.09"	3.94"	2.56"	2.44"	0.39"	M16x1
CAT40-SF1/8-4.72"K	0.125"	0.59"	0.79"	4.72"	3.34"	-	-	-
CAT40-SF3/16-4.72"K	0.187"	0.59"	0.79"	4.72"	3.34"	-	-	-
CAT40-SF1/4-4.72"K	0.250"	0.83"	1.06"	4.72"	3.34"	1.42"	0.39"	M5
CAT40-SF5/16-4.72"K	0.312"	0.83"	1.06"	4.72"	3.34"	1.42"	0.39"	M6
CAT40-SF3/8-4.72"K	0.375"	0.94"	1.26"	4.72"	3.34"	1.65"	0.39"	M8x1
CAT40-SF1/2-4.72"K	0.500"	1.06"	1.34"	4.72"	3.34"	1.85"	0.39"	M10x1
CAT40-SF5/8-4.72"K	0.625"	1.06"	1.34"	4.72"	3.34"	1.97"	0.39"	M12x1
CAT40-SF3/4-4.72"K	0.750"	1.30"	1.65"	4.72"	3.34"	2.05"	0.39"	M16x1
CAT40-SF1-4.72"K	1.000"	1.73"	2.09"	4.72"	3.34"	2.44"	0.39"	M16x1
CAT40-SF1-1/4-4.72"K	1.250"	1.73"	2.09"	4.72"	3.34"	2.44"	0.39"	M16x1
CAT40-SF1/8-6.30"K	0.125"	0.59"	0.79"	6.30"	4.92"	-	-	-
CAT40-SF3/16-6.30"K	0.187"	0.59"	0.79"	6.30"	4.92"	-	-	-
CAT40-SF1/4-6.30"K	0.250"	0.83"	1.26"	6.30"	4.92"	1.42"	0.39"	M5
CAT40-SF5/16-6.30"K	0.312"	0.83"	1.26"	6.30"	4.92"	1.42"	0.39"	M6
CAT40-SF3/8-6.30"K	0.375"	0.94"	1.34"	6.30"	4.92"	1.65"	0.39"	M8x1
CAT40-SF1/2-6.30"K	0.500"	1.06"	1.65"	6.30"	4.92"	1.85"	0.39"	M10x1
CAT40-SF5/8-6.30"K	0.625"	1.06"	1.65"	6.30"	4.92"	1.97"	0.39"	M12x1
CAT40-SF3/4-6.30"K	0.750"	1.30"	1.75"	6.30"	4.92"	2.05"	0.39"	M16x1
CAT40-SF1-6.30"K	1.000"	1.73"	2.09"	6.30"	4.92"	2.44"	0.39"	M16x1
CAT40-SF1-1/4-6.30"K	1.250"	1.73"	2.09"	6.30"	4.92"	2.44"	0.39"	M16x1

Shrink Fit Chuck, 4.5°, Coolant

热缩刀柄, 端面出水型

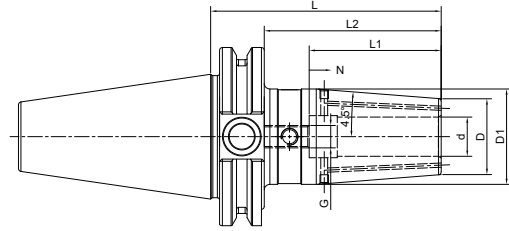
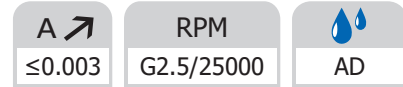

Size	d	D	D1	L	L2	L1	N	G
CAT50-SF1/4-3.15"K	0.250"	0.83"	1.06"	3.15"	2.36"	1.42"	0.39"	M5
CAT50-SF3/8-3.15"K	0.375"	0.94"	1.26"	3.15"	2.36"	1.65"	0.39"	M8x1
CAT50-SF1/2-3.15"K	0.500"	1.06"	1.34"	3.15"	2.36"	1.85"	0.39"	M10x1
CAT50-SF5/8-3.15"K	0.625"	1.06"	1.34"	3.15"	2.36"	1.97"	0.39"	M12x1
CAT50-SF3/4-3.15"K	0.750"	1.30"	1.65"	3.15"	2.36"	2.05"	0.39"	M16x1
CAT50-SF1-3.94"K	1.000"	1.73"	2.09"	3.94"	2.75"	2.44"	0.39"	M16x1
CAT50-SF1-1/4-3.94"K	1.250"	1.73"	2.09"	3.94"	2.75"	2.44"	0.39"	M16x1
CAT50-SF1/4-4.72"K	0.250"	0.83"	1.06"	4.72"	3.35"	1.42"	0.39"	M5
CAT50-SF3/8-4.72"K	0.375"	0.94"	1.26"	4.72"	3.35"	1.65"	0.39"	M8x1
CAT50-SF1/2-4.72"K	0.500"	1.06"	1.34"	4.72"	3.35"	1.85"	0.39"	M10x1
CAT50-SF5/8-4.72"K	0.625"	1.06"	1.34"	4.72"	3.35"	1.97"	0.39"	M12x1
CAT50-SF3/4-4.72"K	0.750"	1.30"	1.65"	4.72"	3.35"	2.05"	0.39"	M16x1
CAT50-SF1-4.72"K	1.000"	1.73"	2.09"	4.72"	3.35"	2.44"	0.39"	M16x1
CAT50-SF1-1/4-4.72"K	1.250"	1.73"	2.09"	4.72"	3.35"	2.44"	0.39"	M16x1
CAT50-SF1/4-6.30"K	0.250"	0.83"	1.26"	6.30"	4.92"	1.42"	0.39"	M5
CAT50-SF3/8-6.30"K	0.375"	0.94"	1.34"	6.30"	4.92"	1.65"	0.39"	M8x1
CAT50-SF1/2-6.30"K	0.500"	1.06"	1.65"	6.30"	4.92"	1.85"	0.39"	M10x1
CAT50-SF5/8-6.30"K	0.625"	1.06"	1.65"	6.30"	4.92"	1.97"	0.39"	M12x1
CAT50-SF3/4-6.30"K	0.750"	1.30"	2.01"	6.30"	4.92"	2.05"	0.39"	M16x1
CAT50-SF1-6.30"K	1.000"	1.73"	2.36"	6.30"	4.92"	2.44"	0.39"	M16x1
CAT50-SF1-1/4-6.30"K	1.250"	1.73"	2.36"	6.30"	4.92"	2.44"	0.39"	M16x1

Shrink Fit Chuck, 4.5°, Coolant 热缩刀柄, 端面出水型

A ↗ ≤0.003	RPM G2.5/25000	AD
---------------	-------------------	----

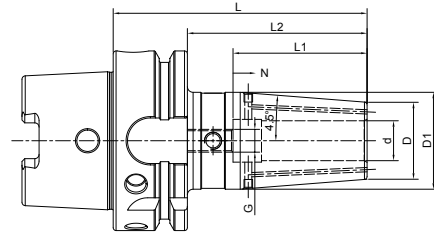

Size	d	D	D1	L	L2	L1	N	G
HSK63A-SF03-80K	3	15	20	80	54	-	-	-
HSK63A-SF04-80K	4	15	20	80	54	-	-	-
HSK63A-SF05-80K	5	15	20	80	54	-	-	-
HSK63A-SF06-80K	6	21	26.5	80	54	36	10	M5
HSK63A-SF08-80K	8	21	26.5	80	54	36	10	M6
HSK63A-SF10-85K	10	24	30.5	85	59	42	10	M8x1
HSK63A-SF12-90K	12	24	31	90	64	47	10	M10x1
HSK63A-SF14-90K	14	27	34	90	64	47	10	M10x1
HSK63A-SF16-95K	16	27	34	95	69	50	10	M12x1
HSK63A-SF18-95K	18	33	41	95	69	50	10	M12x1
HSK63A-SF20-100K	20	33	42	100	74	52	10	M16x1
HSK63A-SF25-115K	25	44	52.5	115	89	58	10	M16x1
HSK63A-SF32-120K	32	44	52.5	120	94	62	10	M16x1
HSK63A-SF03-120K	3	15	20	120	94	-	-	-
HSK63A-SF04-120K	4	15	20	120	94	-	-	-
HSK63A-SF05-120K	5	15	20	120	94	-	-	-
HSK63A-SF06-120K	6	21	27	120	94	36	10	M5
HSK63A-SF08-120K	8	21	27	120	94	36	10	M6
HSK63A-SF10-120K	10	24	32	120	94	42	10	M8x1
HSK63A-SF12-120K	12	24	32	120	94	47	10	M10x1
HSK63A-SF14-120K	14	27	34	120	94	47	10	M10x1
HSK63A-SF16-120K	16	27	34	120	94	50	10	M12x1
HSK63A-SF18-120K	18	33	42	120	94	50	10	M12x1
HSK63A-SF20-120K	20	33	42	120	94	52	10	M16x1
HSK63A-SF25-120K	25	44	52.5	120	94	58	10	M16x1

Shrink Fit Chuck, 4.5°, Coolant 热缩刀柄, 端面出水型

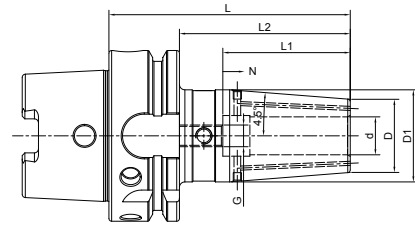
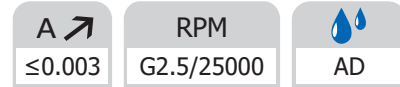

Size	d	D	D1	L	L2	L1	N	G
HSK63A-SF03-160K	3	15	25	160	134	-	-	-
HSK63A-SF04-160K	4	15	25	160	134	-	-	-
HSK63A-SF05-160K	5	15	25	160	134	-	-	-
HSK63A-SF06-160K	6	21	32	160	134	36	10	M5
HSK63A-SF08-160K	8	21	32	160	134	36	10	M6
HSK63A-SF10-160K	10	24	34	160	134	42	10	M8x1
HSK63A-SF12-160K	12	24	34	160	134	47	10	M10x1
HSK63A-SF14-160K	14	27	42	160	134	47	10	M10x1
HSK63A-SF16-160K	16	27	42	160	134	50	10	M12x1
HSK63A-SF18-160K	18	33	51	160	134	50	10	M12x1
HSK63A-SF20-160K	20	33	51	160	134	52	10	M16x1
HSK63A-SF25-160K	25	44	52.5	160	134	58	10	M16x1
HSK63A-SF32-160K	32	44	52.5	160	134	62	10	M16x1
HSK100A-SF06-85K	6	21	26.5	85	56	36	10	M5
HSK100A-SF08-85K	8	21	26.5	85	56	36	10	M6
HSK100A-SF10-90K	10	24	30.5	90	61	42	10	M8x1
HSK100A-SF12-95K	12	24	31	95	66	47	10	M10x1
HSK100A-SF14-95K	14	27	34	95	66	47	10	M10x1
HSK100A-SF16-100K	16	27	34	100	71	50	10	M12x1
HSK100A-SF18-100K	18	33	42	100	71	50	10	M12x1
HSK100A-SF20-105K	20	33	42	105	76	52	10	M16x1
HSK100A-SF25-115K	25	44	53	115	86	58	10	M16x1
HSK100A-SF32-120K	32	44	53	120	91	62	10	M16x1

Shrink Fit Chuck, 4.5°, Coolant
热缩刀柄, 端面出水型

A ↗ ≤0.003	RPM G2.5/25000	AD
---------------	-------------------	----

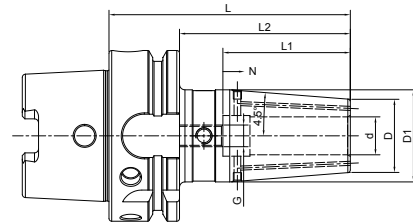

Size	d	D	D1	L	L2	L1	N	G
HSK100A-SF06-120K	6	21	27	120	91	36	10	M5
HSK100A-SF08-120K	8	21	27	120	91	36	10	M6
HSK100A-SF10-120K	10	24	32	120	91	42	10	M8x1
HSK100A-SF12-120K	12	24	32	120	91	47	10	M10x1
HSK100A-SF14-120K	14	27	34	120	91	47	10	M10x1
HSK100A-SF16-120K	16	27	34	120	91	50	10	M12x1
HSK100A-SF18-120K	18	33	42	120	91	50	10	M12x1
HSK100A-SF20-120K	20	33	42	120	91	52	10	M16x1
HSK100A-SF25-120K	25	44	53	120	91	58	10	M16x1
HSK100A-SF06-160K	6	21	32	160	131	36	10	M5
HSK100A-SF08-160K	8	21	32	160	131	36	10	M6
HSK100A-SF10-160K	10	24	34	160	131	42	10	M8x1
HSK100A-SF12-160K	12	24	34	160	131	47	10	M10x1
HSK100A-SF14-160K	14	27	42	160	131	47	10	M10x1
HSK100A-SF16-160K	16	27	42	160	131	50	10	M12x1
HSK100A-SF18-160K	18	33	51	160	131	50	10	M12x1
HSK100A-SF20-160K	20	33	51	160	131	52	10	M16x1
HSK100A-SF25-160K	25	44	60	160	131	58	10	M16x1
HSK100A-SF32-160K	32	44	60	160	131	62	10	M16x1

Shrink Fit Chuck, Slim, 3°

热缩刀柄 3 度, 细长型

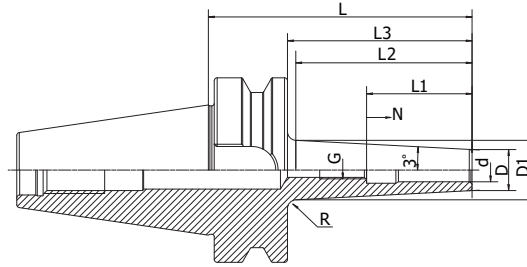
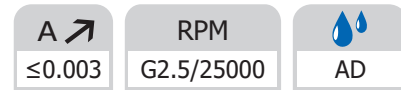

Size	d	D	D1	L	L3	L2	L1	N	G	R
BT30-SFS03-80	3	9	14.8	80	58	55.2	-	-	-	3
BT30-SFS04-80	4	10	15.8	80	58	55.2	-	-	-	3
BT30-SFS06-80	6	12	17.8	80	58	55.2	36	10	M5	3
BT30-SFS08-80	8	14	19.8	80	58	55.2	36	10	M6	3
BT30-SFS10-80	10	16	21.8	80	58	55.2	42	10	M8x1	3
BT30-SFS12-80	12	18	23.8	80	58	55.2	47	10	M10x1	3
BT30-SFS16-80	16	22	27.8	80	58	55.2	50	10	M12x1	3
BT30-SFS06-120	6	12	21.5	120	98	90.6	36	10	M5	3
BT30-SFS08-120	8	14	23.5	120	98	90.6	36	10	M6	3
BT30-SFS10-120	10	16	25.5	120	98	90.6	42	10	M8x1	3
BT30-SFS12-120	12	18	27.5	120	98	90.6	47	10	M10x1	3
BT30-SFS16-120	16	22	31.5	120	98	90.6	50	10	M12x1	3
BT40-SFS03-90	3	9	15.3	90	63	60.2	-	-	-	3
BT40-SFS04-90	4	10	16.3	90	63	60.2	-	-	-	3
BT40-SFS06-90	6	12	18.3	90	63	60.2	36	10	M5	3
BT40-SFS08-90	8	14	20.3	90	63	60.2	36	10	M6	3
BT40-SFS10-90	10	16	22.3	90	63	60.2	42	10	M8x1	3
BT40-SFS12-90	12	18	24.3	90	63	60.2	47	10	M10x1	3
BT40-SFS16-90	16	22	28.3	90	63	60.2	50	10	M12x1	3
BT40-SFS03-120	3	9	18.3	120	93	88.3	-	-	-	5
BT40-SFS04-120	4	10	19.3	120	93	88.3	-	-	-	5
BT40-SFS06-120	6	12	21.3	120	93	88.3	36	10	M5	5
BT40-SFS08-120	8	14	23.3	120	93	88.3	36	10	M6	5
BT40-SFS10-120	10	16	25.3	120	93	88.3	42	10	M8x1	5
BT40-SFS12-120	12	18	27.3	120	93	88.3	47	10	M10x1	5
BT40-SFS16-120	16	22	31.3	120	93	88.3	50	10	M12x1	5
BT40-SFS03-160	3	9	22.4	160	133	128.3	-	-	-	5
BT40-SFS04-160	4	10	23.4	160	133	128.3	-	-	-	5
BT40-SFS06-160	6	12	25.4	160	133	128.3	36	10	M5	5
BT40-SFS08-160	8	14	27.4	160	133	128.3	36	10	M6	5
BT40-SFS10-160	10	16	29.4	160	133	128.3	42	10	M8x1	5
BT40-SFS12-160	12	18	31.4	160	133	128.3	47	10	M10x1	5
BT40-SFS16-160	16	22	35.4	160	133	128.3	50	10	M12x1	5
BT40-SFS20-160	20	27	40.4	160	133	128.3	52	10	M16x1	5

Shrink Fit Chuck, Slim, 3°
热缩刀柄 3 度, 细长型



A ↗ ≤0.003	RPM G2.5/25000	AD
---------------	-------------------	----

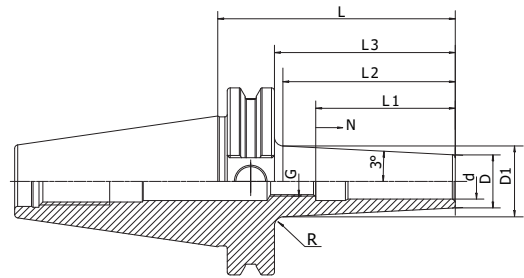

Size	d	D	D1	L	L3	L2	L1	N	G	R
SK40-SFS03-80	3	9	16.1	80	70.9	68.1	-	-	-	3
SK40-SFS04-80	4	10	17.1	80	70.9	68.1	-	-	-	3
SK40-SFS06-80	6	12	19.1	80	70.9	68.1	36	10	M5	3
SK40-SFS08-80	8	14	21.1	80	70.9	68.1	36	10	M6	3
SK40-SFS10-80	10	16	23.1	80	70.9	68.1	42	10	M8x1	3
SK40-SFS12-80	12	18	25.1	80	70.9	68.1	47	10	M10x1	3
SK40-SFS16-80	16	22	29.1	80	70.9	68.1	50	10	M12x1	3
SK40-SFS03-120	3	9	19.1	120	100.9	96.1	-	-	-	5
SK40-SFS04-120	4	10	20.1	120	100.9	96.1	-	-	-	5
SK40-SFS06-120	6	12	22.1	120	100.9	96.1	36	10	M5	5
SK40-SFS08-120	8	14	24.1	120	100.9	96.1	36	10	M6	5
SK40-SFS10-120	10	16	26.1	120	100.9	96.1	42	10	M8x1	5
SK40-SFS12-120	12	18	28.1	120	100.9	96.1	47	10	M10x1	5
SK40-SFS16-120	16	22	32.1	120	100.9	96.1	50	10	M12x1	5
SK40-SFS03-160	3	9	23.3	160	140.9	136.2	-	-	-	5
SK40-SFS04-160	4	10	24.3	160	140.9	136.2	-	-	-	5
SK40-SFS06-160	6	12	26.3	160	140.9	136.2	36	10	M5	5
SK40-SFS08-160	8	14	28.3	160	140.9	136.2	36	10	M6	5
SK40-SFS10-160	10	16	30.3	160	140.9	136.2	42	10	M8x1	5
SK40-SFS12-160	12	18	32.3	160	140.9	136.2	47	10	M10x1	5
SK40-SFS16-160	16	22	36.3	160	140.9	136.2	50	10	M12x1	5

Shrink Fit Chuck, Slim, 3°

热缩刀柄 3 度, 细长型



A ↗ ≤0.003	RPM G2.5/25000	AD
---------------	-------------------	----

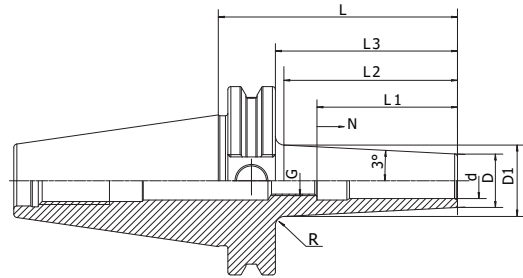

Size	d	D	D1	L	L1	G
CAT40-SFS03-80	3	9	15.5	80	45	M6.0P
CAT40-SFS04-80	4	10	16.3	80	45	M6.0P
CAT40-SFS06-80	6	12	18.3	80	45	M5x0.8P
CAT40-SFS1/8"-3.15"	1/8"	0.35"	0.60"	3.15"	0.78"	M6.0P
CAT40-SFS3/16"-3.15"	3/16"	0.43"	0.68"	3.15"	0.78"	M6.0P
CAT40-SFS1/4"-3.15"	1/4"	0.47"	0.72"	3.15"	1.42"	M5x0.8P
CAT40-SFS3/8"-3.15"	3/8"	0.63"	0.88"	3.15"	1.93"	M8x1.25P
CAT40-SFS1/2"-3.15"	1/2"	0.70"	0.96"	3.15"	1.93"	M10x1.5P

Shrink Fit Chuck, Slim, 3°
热缩刀柄 3 度, 细长型



A ↗ ≤0.003	RPM G2.5/25000	AD
---------------	-------------------	----

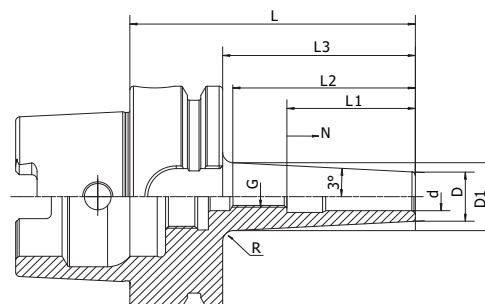

Size	d	D	D1	L	L3	L2	L1	N	G	R
HSK50A-SFS03-80	3	9	14.4	80	54	51.2	-	-	-	3
HSK50A-SFS04-80	4	10	15.4	80	54	51.2	-	-	-	3
HSK50A-SFS06-80	6	12	17.4	80	54	51.2	36	10	M5	3
HSK50A-SFS08-80	8	14	19.4	80	54	51.2	36	10	M6	3
HSK50A-SFS10-85	10	16	21.9	85	59	56.2	42	10	M8x1	3
HSK50A-SFS12-90	12	18	24.4	90	64	61.2	47	10	M10x1	3
HSK50A-SFS16-95	16	22	28.9	95	69	66.2	50	10	M12x1	3
HSK63A-SFS03-80	3	9	14	80	54	47.7	-	-	-	4
HSK63A-SFS04-80	4	10	15.4	80	54	51.2	-	-	-	3
HSK63A-SFS06-80	6	12	17.4	80	54	51.2	36	10	M5	3
HSK63A-SFS08-80	8	14	19.4	80	54	51.2	36	10	M6	3
HSK63A-SFS10-85	10	16	21.8	85	59	56.2	42	10	M8x1	3
HSK63A-SFS12-90	12	18	24.4	90	64	61.2	47	10	M10x1	3
HSK63A-SFS16-95	16	22	28.7	95	69	64.3	50	10	M12x1	5
HSK63A-SFS03-120	3	9	18.4	120	94	89.3	-	-	-	5
HSK63A-SFS04-120	4	10	19.4	120	94	89.3	-	-	-	5
HSK63A-SFS06-120	6	12	21.4	120	94	89.3	36	10	M5	5
HSK63A-SFS08-120	8	14	23.4	120	94	89.3	36	10	M6	5
HSK63A-SFS10-120	10	16	25.4	120	94	89.3	42	10	M8x1	5
HSK63A-SFS12-120	12	18	27.4	120	94	89.3	47	10	M10x1	5
HSK63A-SFS16-120	16	22	31.4	120	94	89.3	50	10	M12x1	5
HSK63A-SFS03-160	3	9	22.5	160	134	129.3	-	-	-	5
HSK63A-SFS04-160	4	10	23.5	160	134	129.3	-	-	-	5
HSK63A-SFS06-160	6	12	25.5	160	134	129.3	36	10	M5	5
HSK63A-SFS08-160	8	14	27.5	160	134	129.3	36	10	M6	5
HSK63A-SFS10-160	10	16	29.5	160	134	129.3	42	10	M8x1	5
HSK63A-SFS12-160	12	18	31.5	160	134	129.3	47	10	M10x1	5
HSK63A-SFS16-160	16	22	35.5	160	134	129.3	50	10	M12x1	5

Shrink Fit Chuck, Slim, 3°

热缩刀柄 3 度, 细长型

A ↗ ≤0.003	RPM G2.5/25000	AD
---------------	-------------------	----

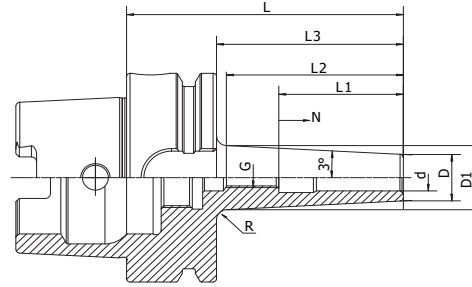

Size	d	D	L	L3	L1	N	G
HSK63A-SFS1/8-3.15"	0.125"	0.59"	3.15"	2.13"	-	-	-
HSK63A-SFS3/16-3.15"	0.187"	0.59"	3.15"	2.13"	-	-	-
HSK63A-SFS1/4-3.15"	0.250"	0.83"	3.15"	2.13"	1.42"	0.39"	M5
HSK63A-SFS5/16-3.15"	0.312"	0.83"	3.15"	2.13"	1.42"	0.39"	M6
HSK63A-SFS3/8-3.35"	0.375"	0.94"	3.35"	2.32"	1.65"	0.39"	M8x1
HSK63A-SFS1/2-3.54"	0.500"	1.06"	3.54"	2.52"	1.85"	0.39"	M10x1

Shrink Fit Chuck, Slim, 3°
热缩刀柄 3度, 细长型

A ↗ ≤0.003	RPM G2.5/25000	AD
---------------	-------------------	----

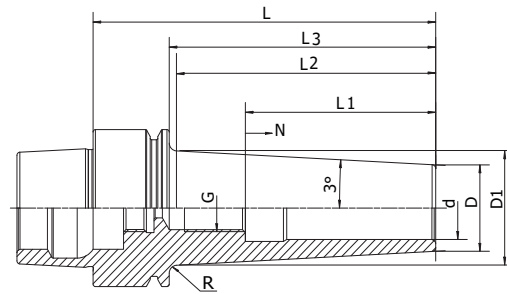

Size	d	D	D1	L	L3	L2	L1	N	G	R
HSK25E-SFS03-50	3	9	—	50	33	—	23	8	M6	—
HSK25E-SFS04-50	4	10	—	50	33	—	20	4	M6	—
HSK25E-SFS05-50	5	11	—	50	33	—	20	3	M6	—
HSK25E-SFS06-50	6	12	—	50	33	—	36	—	—	—
HSK25E-SFS08-50	8	14	—	50	38	—	36	—	—	—
HSK25E-SFS10-50	10	16	—	50	40	—	42	—	—	—
HSK32E-SFS03-60	3	9	13.3	60	44	41.2	20	5	M6	3
HSK32E-SFS04-60	4	10	14.3	60	44	41.2	20	5	M6	3
HSK32E-SFS06-70	6	12	17.4	70	54	51.2	36	5	M5	3
HSK32E-SFS08-70	8	14	19.36	70	54	51.2	36	5	M6	3
HSK32E-SFS10-80	10	16	22.4	80	64	61.2	42	5	M8x1	3
HSK40E-SFS03-50	3	9	11.9	50	30	27.2	20	—	—	3
HSK40E-SFS04-50	4	10	12.9	50	30	27.2	20	—	—	3
HSK40E-SFS06-60	6	12	15.9	60	40	37.2	36	10	M5	3
HSK40E-SFS08-60	8	14	17.9	60	40	37.2	36	10	—	3
HSK40E-SFS10-60	10	16	19.9	60	40	37.2	42	10	—	3
HSK40E-SFS12-60	12	18	21.9	60	40	37.2	42	10	—	3
HSK40E-SFS16-70	16	22	27	70	50	48.1	50	10	—	2
HSK50E-SFS03-60	3	9	12.3	60	34	31.2	20	—	—	3
HSK50E-SFS04-80	4	10	15.4	80	54	51.2	20	—	—	3
HSK50E-SFS06-80	6	12	17.4	80	54	51.2	36	10	M5	3
HSK50E-SFS08-80	8	14	19.4	80	54	51.2	36	10	M6	3
HSK50E-SFS10-90	10	16	22.4	90	64	61.2	42	10	M8x1	3
HSK50E-SFS12-90	12	18	24.4	90	64	61.2	47	10	M10x1	3
HSK50E-SFS16-90	16	22	28.4	90	64	61.2	50	10	M16x1	3

Shrink Fit Chuck, Slim, 3°

热缩刀柄 3 度, 细长型

A ↗ ≤0.003	RPM G2.5/25000	AD
---------------	-------------------	----

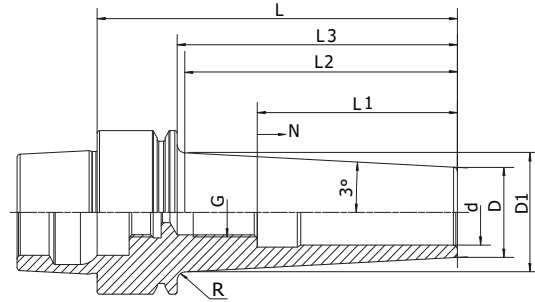

Size	d	D	D1	L	L3	L1	N	G
HSK40E-SFS1/8-2.36"	1/8"	0.36"	0.63"	2.36"	1.57"	0.78"	–	M6 x 1.0
HSK40E-SFS3/16-2.36"	3/16"	0.43"	0.69"	2.36"	1.57"	0.78"	–	M6 x 1.0
HSK40E-SFS1/4-2.36"	1/4"	0.47"	0.81"	2.36"	1.57"	1.42"	0.39"	M5 x 0.8
HSK40E-SFS3/8-2.36"	3/8"	0.63"	0.94"	2.36"	1.57"	1.65"	0.39"	M8 x 1.25
HSK40E-SFS1/2-2.36"	1/2"	0.71"	1.06"	2.36"	1.57"	1.85"	0.39"	M10 x 1.5
HSK50E-SFS1/8-2.76	0.125	0.39	0.55	2.76	1.65	0.79	–	M6
HSK50E-SFS3/16-2.76	0.187	0.39	0.55	2.76	1.65	0.98	–	M6
HSK50E-SFS1/4-2.76	0.25	0.47	0.63	2.76	1.65	1.42	0.39"	M5
HSK50E-SFS3/8-2.76	0.375	0.63	0.79	2.76	1.65	1.65	0.39"	
HSK50E-SFS1/2-2.76	0.5	0.71	0.87	2.76	1.65	1.85	0.39"	–
HSK50E-SFS5/8-2.76	0.625	0.87	1.02	2.76	1.65	1.85	0.39"	–
HSK50E-SFS1/4-3.54	0.25	0.47	0.71	3.54	2.36	1.42	0.39"	M5
HSK50E-SFS3/8-3.54	0.375	0.63	0.87	3.54	2.36	1.65	0.39"	M8x1
HSK50E-SFS1/2-3.54	0.5	0.79	1.02	3.54	2.36	1.85	0.39"	M10x1
HSK50E-SFS5/8-3.54	0.625	0.87	1.1	3.54	2.36	1.97	0.39"	M10x1
HSK50E-SFS1/8-3.94	0.125	0.39	0.67	3.94	2.76	0.79	–	M6
HSK50E-SFS3/16-3.94	0.187	0.43	0.71	3.94	2.76	0.98	–	M6
HSK50E-SFS1/4-4.72	0.25	0.47	0.83	4.72	3.54	1.42	0.39"	M5
HSK50E-SFS3/8-4.72	0.375	0.63	0.98	4.72	3.54	1.65	0.39"	M8x1
HSK50E-SFS1/2-4.72	0.5	0.79	1.14	4.72	3.54	1.85	0.39"	M10x1
HSK50E-SFS5/8-4.72	0.625	0.87	1.22	4.72	3.54	1.97	0.39"	M10x1

Shrink Fit Extension, 3° 3° 直柄热缩延长杆

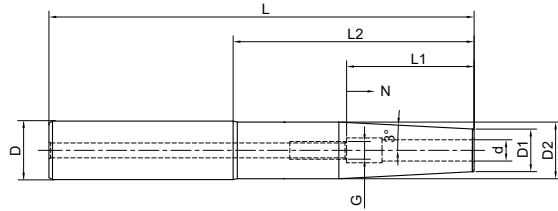

Size	d	D1	D2	D	L	L1	L2	N	G	
C12-SFS03-120	3	9	11.8	12	120	-	73	-	-	1
C12-SFS04-120	4	10	11.8	12	120	-	73	-	-	1
C12-SFS05-120	5	11	11.8	12	120	-	73	-	-	1
C12-SFS06-120	6	12	17	12	120	36	73	10	M5	3
C12-SFS08-120	8	14	19	12	120	36	73	10	M6	3
C16-SFS03-120	3	9	13	16	120	-	70	-	-	1
C16-SFS04-120	4	10	14	16	120	-	70	-	-	1
C16-SFS05-120	5	11	15	16	120	-	70	-	-	1
C16-SFS06-120	6	12	15.8	16	120	36	70	10	M5	2
C16-SFS08-120	8	14	19	16	120	36	70	10	M6	3
C20-SFS03-120	3	9	13	20	120	-	68	-	-	1
C20-SFS04-120	4	10	14	20	120	-	68	-	-	1
C20-SFS05-120	5	11	15	20	120	-	68	-	-	1
C20-SFS06-120	6	12	16	20	120	36	68	10	M5	1
C20-SFS08-120	8	14	19	20	120	36	68	10	M6	1
C20-SFS10-120	10	16	19.8	20	120	42	68	10	M8x1	1
C20-SFS12-120	12	18	19.8	20	120	47	68	10	M10x1	1
C12-SFS03-160	3	9	11.8	12	160	-	113	-	-	1
C12-SFS04-160	4	10	11.8	12	160	-	113	-	-	1
C16-SFS03-160	3	9	13	16	160	-	110	-	-	1
C16-SFS04-160	4	10	14	16	160	-	110	-	-	1
C16-SFS05-160	5	11	15	16	160	-	110	-	-	1
C20-SFS05-160	5	11	15	20	160	-	110	-	-	1
C20-SFS06-160	6	12	16	20	160	36	108	10	M5	1
C20-SFS08-160	8	14	19	20	160	36	108	10	M6	1
C25-SFS08-160	8	14	19	25	160	36	108	10	M6	1
C25-SFS10-160	10	16	21	25	160	42	108	10	M8x1	1
C25-SFS12-160	12	18	23	25	160	47	108	10	M10x1	1
C25-SFS14-160	14	20	24.8	25	160	47	108	10	M10x1	1
C25-SFS16-160	16	22	24.8	25	160	50	108	10	M12x1	1
C32-SFS10-160	10	16	21	32	160	42	98	10	M8x1	1
C32-SFS12-160	12	18	23	32	160	47	98	10	M10x1	1

Shrink Fit Extension, 3°

3° 直柄热缩延长杆

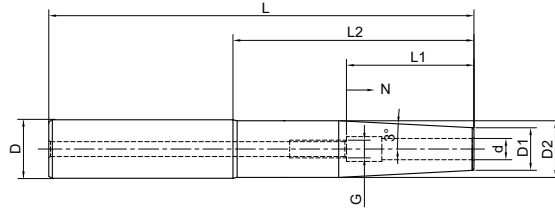

Size	d	D1	D2	D	L	L1	L2	N	G
C32-SFS14-160	14	20	25	32	160	47	98	10	M10x1
C32-SFS16-160	16	22	28	32	160	50	98	10	M12x1
C32-SFS18-160	18	25	30	32	160	50	98	10	M12x1
C32-SFS20-160	20	26	31.8	32	160	52	98	10	M16x1
C16-SFS03-200	3	9	13	16	200	-	150	-	-
C16-SFS04-200	4	10	14	16	200	-	150	-	-
C16-SFS05-200	5	11	15	16	200	-	150	-	-
C16-SFS06-200	6	12	15.8	16	200	36	150	10	M5
C16-SFS08-200	8	14	19	16	200	36	150	10	M6
C20-SFS04-200	4	10	14	20	200	-	148	-	-
C20-SFS06-200	6	12	16	20	200	36	148	10	M5
C20-SFS08-200	8	14	19	20	200	36	148	10	M6
C20-SFS10-200	10	16	19.8	20	200	42	148	10	M8x1
C20-SFS06-250	6	12	16	20	250	36	198	10	M5
C20-SFS08-250	8	14	19	20	250	36	198	10	M6
C20-SFS10-250	10	16	19.8	20	250	42	198	10	M8x1
C25-SFS12-250	12	18	23	25	250	47	192	10	M10x1
C25-SFS16-250	16	22	28	25	250	50	192	10	M12x1

Shrink Fit Extension, 3° 3° 直柄热缩延长杆

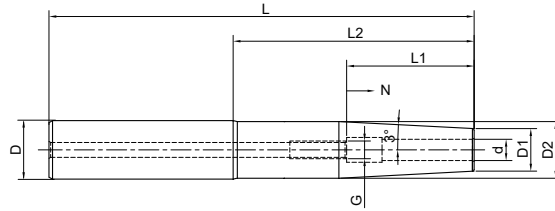

Size	d	D1	D2	D	L	L1	L2	N	G
C1/2-1/8-4.33	1/8	0.39	1/2	1/2	4.33	0.79	2.48	0.2	M6
C3/4-1/8-4.33	1/8	0.39	3/4	3/4	4.33	0.98	2.28	0.2	M6
C1/2-1/4-4.33	1/4	0.47	1/2	1/2	4.33	1.42	2.48	0.39	M5
C3/4-1/4-4.33	1/4	0.47	3/4	3/4	4.33	1.42	2.28	0.39	M5
C3/4-3/8-4.33	3/8	0.63	3/4	3/4	4.33	1.65	2.28	0.39	M8*1
C3/4-1/8-9.84	1/8	0.39	3/4	3/4	9.84	0.79	7.79	0.2	M6
C3/4-1/4-9.84	1/4	0.47	3/4	3/4	9.84	1.42	7.79	0.39	M5
C3/4-3/8-9.84	3/8	0.63	3/4	3/4	9.84	1.65	7.79	0.39	M8*1
C3/4-1/2-9.84	1/2	0.79	1	3/4	9.84	1.85	7.59	0.39	M10*1
C1-1/2-9.84	1/2	0.87	1	1	9.84	1.85	7.59	0.39	M10*1
C1-5/8-9.84	5/8	0.87	1	1	9.84	1.97	7.59	0.39	M12*1

Module Shrink Chuck 法兰热缩刀柄



A ↗
≤0.003

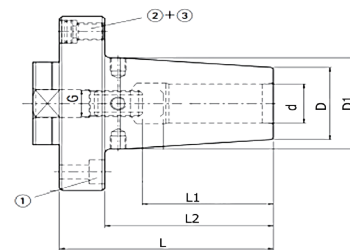

Size	d	D	D1	L	L2	L1	N	G
MOD60-SF06-70	6	21	27	70	57	36	10	M5
MOD60-SF08-70	8	21	27	70	57	36	10	M6
MOD60-SF10-70	10	24	32	70	57	41	10	M8x1
MOD60-SF12-70	12	24	32	70	57	46	10	M10x1
MOD70-SF14-75	14	27	34	75	60	46	10	M10x1
MOD70-SF16-75	16	27	34	75	60	49	10	M12x1
MOD80-SF18-80	18	33	42	80	63	49	10	M12x1
MOD80-SF20-80	20	33	42	80	63	51	10	M16x1
MOD100-SF25-80	25	44	53	80	59	57	10	M16x1
MOD100-SF32-80	32	44	53	80	59	61	10	M16x1

Shrink Fit ER Collet

ER 热缩夹头

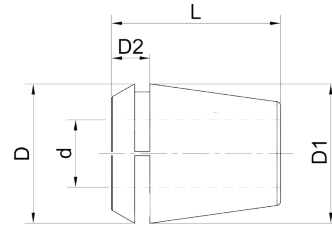

Size	Collet Size	d	D1	D2	L
ER16-SF03	ER16	3	16	6.7	27.5
ER16-SF04	ER16	4	16	6.7	27.5
ER16-SF05	ER16	5	16	6.7	27.5
ER16-SF06	ER16	6	16	6.7	27.5
ER16-SF08	ER16	8	16	6.7	27.5
ER16-SF10	ER16	10	16	6.7	27.5
ER20-SF03	ER20	3	20	7.52	31.5
ER20-SF04	ER20	4	20	7.52	31.5
ER20-SF05	ER20	5	20	7.52	31.5
ER20-SF06	ER20	6	20	7.52	31.5
ER20-SF08	ER20	8	20	7.52	31.5
ER20-SF10	ER20	10	20	7.52	31.5
ER20-SF12	ER20	12	20	7.52	31.5
ER25-SF03	ER25	3	25	8	34
ER25-SF04	ER25	4	25	8	34
ER25-SF05	ER25	5	25	8	34
ER25-SF06	ER25	6	25	8	34
ER25-SF08	ER25	8	25	8	34
ER25-SF10	ER25	10	25	8	34
ER25-SF12	ER25	12	25	8	34
ER25-SF14	ER25	14	25	8	34
ER25-SF16	ER25	16	25	8	34
ER32-SF03	ER32	3	32	9	40
ER32-SF04	ER32	4	32	9	40
ER32-SF05	ER32	5	32	9	40
ER32-SF06	ER32	6	32	9	40
ER32-SF08	ER32	8	32	9	40
ER32-SF10	ER32	10	32	9	40
ER32-SF12	ER32	12	32	9	40
ER32-SF14	ER32	14	32	9	40
ER32-SF16	ER32	16	32	9	40
ER32-SF18	ER32	18	32	9	40
ER32-SF20	ER32	20	32	9	40

Shrink Fit ER Collet Extension ER 热缩延长杆

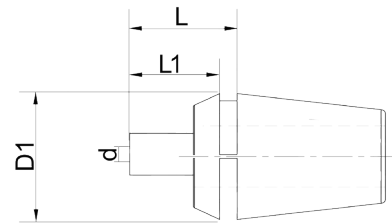

Size	Collet Size	d	D1	L	L1
ER16-SFS03-35	ER16	3	16	41.7	35
ER16-SFS04-35	ER16	4	16	41.7	35
ER16-SFS05-35	ER16	5	16	41.7	35
ER16-SFS06-35	ER16	6	16	41.7	35
ER20-SFS03-35	ER20	3	20	42.52	35
ER20-SFS04-35	ER20	4	20	42.52	35
ER20-SFS05-35	ER20	5	20	42.52	35
ER20-SFS06-35	ER20	6	20	42.52	35
ER20-SFS08-35	ER20	8	20	42.52	35
ER25-SFS03-35	ER25	3	25	43	35
ER25-SFS04-35	ER25	4	25	43	35
ER25-SFS05-35	ER25	5	25	43	35
ER25-SFS06-35	ER25	6	25	43	35
ER25-SFS08-35	ER25	8	25	43	35
ER25-SFS10-35	ER25	10	25	43	35
ER32-SFS03-35	ER32	3	32	44	35
ER32-SFS04-35	ER32	4	32	44	35
ER32-SFS05-35	ER32	5	32	44	35
ER32-SFS06-35	ER32	6	32	44	35
ER32-SFS08-35	ER32	8	32	44	35
ER32-SFS10-35	ER32	10	32	44	35
ER32-SFS12-35	ER32	12	32	44	35
ER32-SFS14-35	ER32	14	32	44	35
ER32-SFS16-35	ER32	16	32	44	35

Shrink Chuck Set

热缩刀柄套装

A ↗
≤0.003

RPM
G2.5/25000

 AD
--



Size	Tool Holder Size	Extension Size	Extension Quantity
BT40-SF16-90-4 pcs	BT40-SF16-90	C16-SFS03/04/06/08-160	4
BT40-SF16-90-4 pcs	BT40-SF16-90	C16-SFS03/04/06/08-160	4
BT40-SF20-90-6 pcs	BT40-SF20-90	C20-SFS03/04/06/08/10/12-160	6
SK40-SF16-90-4 pcs	SK40-SF16-90	C12-SFS03/04/06/08-160	4
SK40-SF16-90-4 pcs	SK40-SF16-90	C16-SFS03/04/06/08-160	4
SK40-SF20-90-6 pcs	SK40-SF20-90	C20-SFS03/04/06/08/10/12-160	6
HSK63A-SF16-90-4 pcs	HSK63A-SF16-90	C12-SFS03/04/06/08-160	4
HSK63A-SF16-90-4 pcs	HSK63A-SF16-90	C16-SFS03/04/06/08-160	4
HSK63A-SF20-90-6 pcs	HSK63A-SF20-90	C20-SFS03/04/06/08/10/12-160	6

Shrink Chuck Taper
分体热缩本体，标准型

A ↗ ≤0.003	RPM G2.5/25000	AD
----------------------	--------------------------	-----------

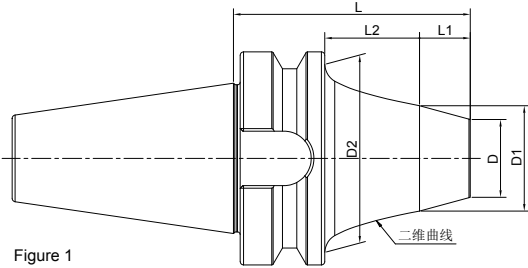

Figure 1

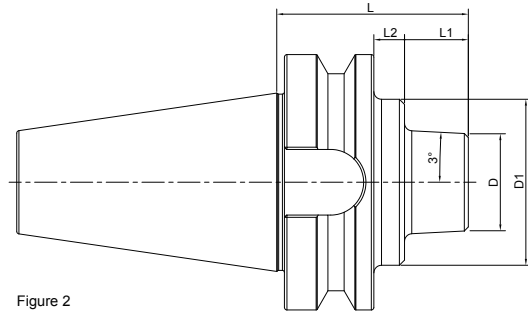

Figure 2

Size	D	D1	D2	L	L1	L2	Figure
BT30-TSF06-35	19	-	34	35	13	-	1
BT30-TSF08-35	23	-	34	35	13	-	1
BT30-TSF12-35	38	-	-	35	13	-	2
BT40-TSF08-40	23	-	53	40	13	-	1
BT40-TSF12-45	38	-	-	45	18	-	2
BT40-TSF12-75	38	-	-	75	48	-	2
BT40-TSF12-135	41	-	-	135	108	-	2
BT50-TSF12-75	38	65	-	75	25	12	2
BT50-TSF12-105	41	66	-	105	55	12	2
BT50-TSF12-135	41	67	-	135	85	12	2

Shrink Chuck Taper

分体热缩本体, 标准型

A ↗	RPM	
≤0.003	G2.5/25000	AD

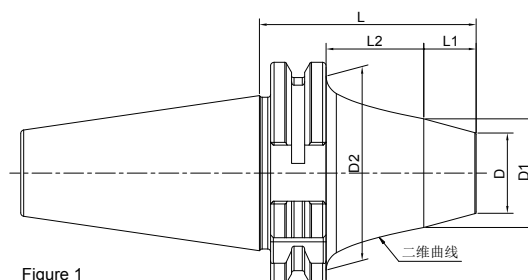

Figure 1

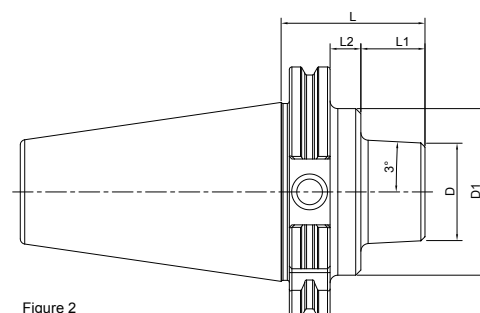

Figure 2

Size	D	D1	D2	L	L1	L2	Figure
SK30-TSF06-35	19	-	34	35	13	-	1
SK30-TSF08-35	23	27.5	34	35	13	-	1
SK30-TSF12-35	38	-	-	35	13	-	2
SK40-TSF08-40	23	31.2	50	40	13	-	1
SK40-TSF12-45	38	-	-	45	18	-	2
SK40-TSF12-75	38	-	-	75	48	-	2
SK40-TSF12-135	38	-	-	135	108	-	-
SK50-TSF12-75	38	65	-	75	25	12	2
SK50-TSF12-105	38	65	-	105	55	12	2
SK50-TSF12-135	38	65	-	135	85	12	2

Shrink Chuck Taper
分体热缩本体，标准型

A ↗ ≤0.003	RPM G2.5/25000	AD
---------------	-------------------	----

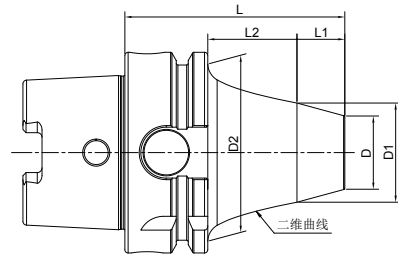

Figure 1

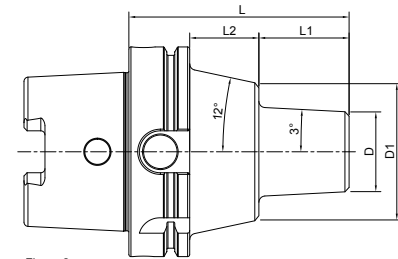



Figure 2

Size	D	D1	D2	L	L1	L2	Figure
HSK50A-TSF06-55	19	24.6	42	55	7	22	1
HSK50A-TSF08-55	23	28.1	42	55	7	22	1
HSK50A-TSF12-75	38	-	-	75	49	-	2
HSK63A-TSF08-55	23	29.5	53	55	7	22	1
HSK63A-TSF12-75	38	-	-	75	49	-	2
HSK63A-TSF12-135	38	-	-	135	109	-	2
HSK100A-TSF12-105	38	65	-	105	43	33	2

Shrink Chuck Taper

分体热缩本体, 标准型

A ↗ ≤0.003	RPM G2.5/25000	 AD
---------------	-------------------	---

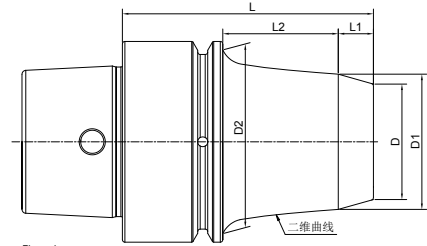

Figure 1

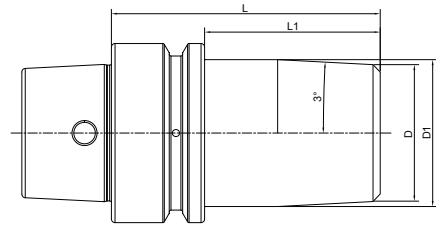

Figure 2

Size	D	D1	D2	L	L1	L2	Figure
HSK32E-TSF06-50	19	26	-	50	7	23	1
HSK40E-TSF06-50	19	23.5	34	50	7	23	1
HSK40E-TSF08-50	23	27	34	50	7	23	1
HSK50E-TSF06-55	19	24.6	42	55	7	22	1
HSK50E-TSF08-55	23	28.1	42	55	7	22	1
HSK50E-TSF12-75	38	-	-	75	49	-	2

Shrink Chuck Taper
分体热缩本体, 标准型

A ↗ ≤0.003	RPM G2.5/25000	AD
----------------------	--------------------------	-----------

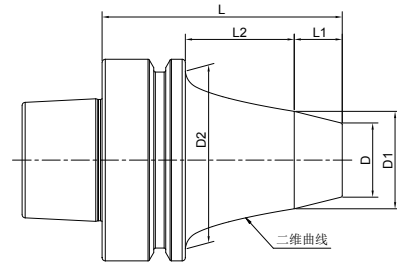

Figure 1

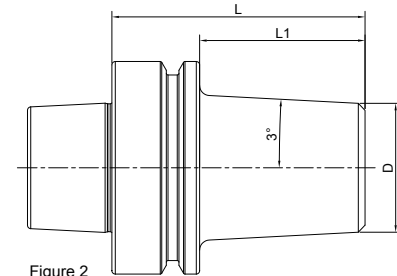
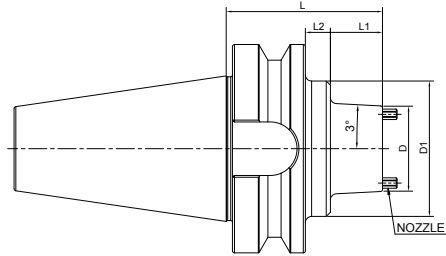

Figure 2

Size	D	D1	D2	L	L1	L2	Figure
HSK63F-TSF08-55	23	29.5	53	55	7	22	1
HSK63F-TSF12-75	38	-	-	75	49	-	2

Shrink Chuck Taper, Coolant 分体热缩本体, 端面出水型

A ↗ ≤0.003	RPM G2.5/25000	AD
---------------	-------------------	----



Size	D	D1	L	L1	L2
BT40-TSF12-45K	41	-	45	18	-
BT40-TSF12-75K	41	-	75	48	-
BT40-TSF12-135K	41	-	135	108	-
BT50-TSF12-75K	41	65	75	25	12
BT50-TSF12-105K	41	65	105	55	12
BT50-TSF12-135K	41	65	135	85	12

Tool Holder DIN 69871

Shrink Chuck Taper, Coolant 分体热缩本体, 端面出水型

A ↗ ≤0.003	RPM G2.5/25000	AD
---------------	-------------------	----

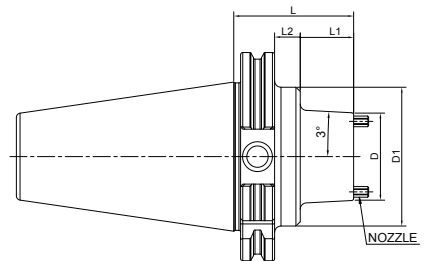

Size	D	D1	L	L1	L2
SK40-TSF12-45K	41	-	45	25.9	-
SK40-TSF12-75K	41	-	75	55.9	-
SK40-TSF12-135K	41	44	135	28.6	87.3
SK50-TSF12-75K	41	65	75	43.9	12
SK50-TSF12-105K	41	65	105	73.9	12
SK50-TSF12-135K	41	65	135	103.9	12

Shrink Chuck Taper, Coolant
分体热缩本体，端面出水型

A ↗ ≤0.003	RPM G2.5/25000	AD
---------------	-------------------	----

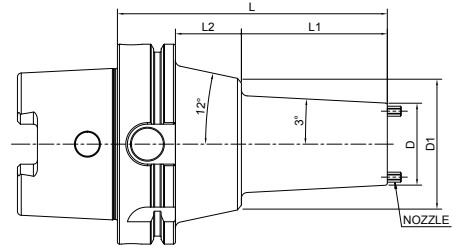

Size	D	D1	L	L1	L2
HSK63A-TSF12-75K	41	-	75	49	-
HSK63A-TSF12-135K	41	-	135	109	-
HSK100A-TSF12-105K	41	65	105	43	33
HSK100A-TSF12-135K	41	65	135	73	33

Shrink Chuck Extension, Slim 分体热缩延长杆, 细长型

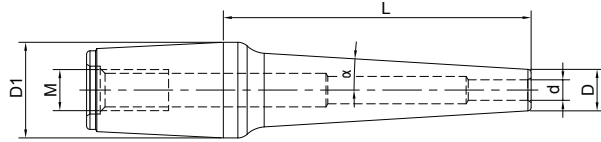
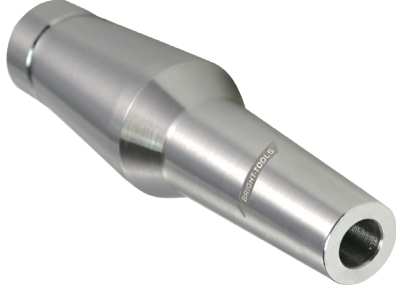

Size	d	D	D1	L	M	α
12-SF3-35S	3	6	26	35	M10	3
12-SF3-55S	3	6	26	55	M10	3
12-SF3-80S	3	6	26	80	M10	3
12-SF3-110S	3	6	26	110	M10	3
12-SF4-35S	4	7	26	35	M10	3
12-SF4-55S	4	7	26	55	M10	3
12-SF4-80S	4	7	26	80	M10	3
12-SF4-110S	4	7	26	110	M10	3
12-SF5-35S	5	8	26	35	M10	3
12-SF5-55S	5	8	26	55	M10	3
12-SF5-80S	5	8	26	80	M10	3
12-SF5-110S	5	8	26	110	M10	3
12-SF6-35S	6	9	26	35	M10	3
12-SF6-55S	6	9	26	55	M10	3
12-SF6-80S	6	9	26	80	M10	3
12-SF6-110S	6	9	26	110	M10	3
12-SF7-35S	7	10	26	35	M10	3
12-SF7-55S	7	10	26	55	M10	3
12-SF7-80S	7	10	26	80	M10	3
12-SF7-110S	7	10	26	110	M10	3
12-SF8-35S	8	11	26	35	M10	3
12-SF8-55S	8	11	26	55	M10	3
12-SF8-80S	8	11	26	80	M10	3
12-SF8-110S	8	11	26	110	M10	3

Shrink Chuck Extension, Slim 分体热缩延长杆, 细长型

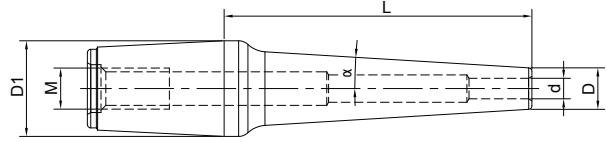

Size	d	D	D1	L	M	α
12-SF9-35S	9	12	26	35	M10	3
12-SF9-55S	9	12	26	55	M10	3
12-SF9-80S	9	12	26	80	M10	3
12-SF9-110S	9	12	26	110	M10	3
12-SF10-35S						
	10	13	26	35	M10	3
12-SF10-55S	10	13	26	55	M10	3
12-SF10-80S	10	13	26	80	M10	3
12-SF10-110S	10	13	26	110	M10	3
12-SF11-35S						
	11	14	26	35	M10	3
12-SF11-55S	11	14	26	55	M10	3
12-SF11-80S	11	14	26	80	M10	3
12-SF11-110S	11	14	26	110	M10	3
12-SF12-35S						
	12	15	26	35	M10	3
12-SF12-55S	12	15	26	55	M10	3
12-SF12-80S	12	15	26	80	M10	3
12-SF12-110S	12	15	26	110	M10	3

Inch

Size	d	D	D1	L	M	α
12-SF3.175-35S	3.175	6.175	26	35	M10	3
12-SF3.175-55S	3.175	6.175	26	55	M10	3
12-SF3.175-80S	3.175	6.175	26	80	M10	3
12-SF3.175-110S	3.175	6.175	26	110	M10	3

Shrink Chuck Extension, Standard

分体热缩延长杆, 标准型

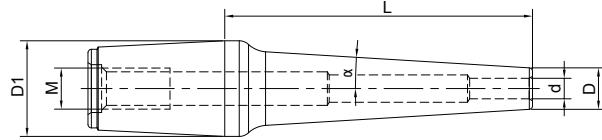

Size	d	D	D1	L	M	α
12-SF3-35	3	7.5	26	35	M10	3
12-SF3-55	3	7.5	26	55	M10	3
12-SF3-80	3	7.5	26	80	M10	3
12-SF4-35	4	10	26	35	M10	3
12-SF4-55	4	10	26	55	M10	3
12-SF4-80	4	10	26	80	M10	3
12-SF6-35	6	12	26	35	M10	3
12-SF6-55	6	12	26	55	M10	3
12-SF6-80	6	12	26	80	M10	3
12-SF8-35	8	14	26	35	M10	3
12-SF8-55	8	14	26	55	M10	3
12-SF8-80	8	14	26	80	M10	3
12-SF10-35	10	16	26	35	M10	3
12-SF10-55	10	16	26	55	M10	3
12-SF10-80	10	16	26	80	M10	3
12-SF12-35	12	20	26	35	M10	3
12-SF12-55	12	20	26	55	M10	3
12-SF12-80	12	20	26	80	M10	3

Shrink Chuck Extension, Coolant 分体热缩延长杆, 端面出水型

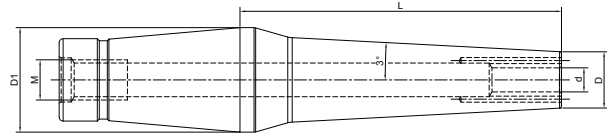

Size	d	D	D1	L	M
12-SF3-35K	3	9.5	26	35	M10
12-SF3-55K	3	9.5	26	55	M10
12-SF3-80K	3	9.5	26	80	M10
12-SF4-35K	4	12	26	35	M10
12-SF4-55K	4	12	26	55	M10
12-SF4-80K	4	12	26	80	M10
12-SF6-35K	6	14	26	35	M10
12-SF6-55K	6	14	26	55	M10
12-SF6-80K	6	14	26	80	M10
12-SF8-35K	8	16	26	35	M10
12-SF8-55K	8	16	26	55	M10
12-SF8-80K	8	16	26	80	M10
12-SF10-35K	10	18	26	35	M10
12-SF10-55K	10	18	26	55	M10
12-SF10-80K	10	18	26	80	M10
12-SF12-35K	12	20	26	35	M10
12-SF12-55K	12	20	26	55	M10
12-SF12-80K	12	20	26	80	M10

Shrink Chuck Set

热缩刀柄套装

A ↗
≤0.003

RPM
G2.5/25000

 AD
--



Size	Tool Holder Size	Extension Size	Extension Quantity
BT40-TSF08-40-4 pcs	BT40-TSF08-40	8-SF3/4/6/8-45S	4
BT40-TSF08-70-4 pcs	BT40-TSF08-70	8-SF3/4/6/8-45S	4
BT40-TSF12-45-6 pcs	BT40-TSF12-45	12-SF3/4/6/8/10/12-80S	6
BT40-TSF12-75-6 pcs	BT40-TSF12-75	12-SF3/4/6/8/10/12-80S	6
SK40-TSF08-40-4 pcs	SK40-TSF08-40	8-SF3/4/6/8-45S	4
SK40-TSF08-70-4 pcs	SK40-TSF08-70	8-SF3/4/6/8-45S	4
SK40-TSF12-45-6 pcs	SK40-TSF12-45	12-SF3/4/6/8/10/12-80S	6
SK40-TSF12-75-6 pcs	SK40-TSF12-75	12-SF3/4/6/8/10/12-80S	6
HSK63A-TSF08-55-4 pcs	HSK63A-TSF08-55	8-SF3/4/6/8-45S	4
HSK63A-TSF08-75-4 pcs	HSK63A-TSF08-75	8-SF3/4/6/8-45S	4
HSK63A-TSF12-75-6 pcs	HSK63A-TSF12-75	12-SF3/4/6/8/10/12-80S	6
HSK63F-TSF08-55-4 pcs	HSK63F-TSF08-55	8-SF3/4/6/8-45S	4
HSK63F-TSF08-75-4 pcs	HSK63F-TSF08-75	8-SF3/4/6/8-45S	4
HSK63F-TSF12-75-6 pcs	HSK63F-TSF12-75	12-SF3/4/6/8/10/12-80S	6

Shrink Fit Machine, Standard 热缩机, 标准型

- Inductive shrink fit technology
- 7"-Touch-Display, automatic parameter setting, simplified usability
- Used for carbide cutting tools

- 电磁感应加热技术
- 7寸触摸屏，自动化参数设置，使用简单
- 适用于硬质合金刀具

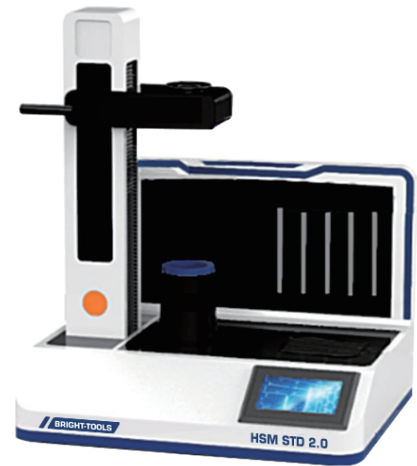

Size	Power	Power	D	DxWxH
HSM STD 2.0	380V 50HZ	13KW	Φ3-Φ32	740×580×845